

# Fabrication and Applications of Fiber Bragg Grating- A Review

Sanjeev Dewra<sup>1</sup>, Vikas<sup>2</sup> and Amit Grover<sup>2,\*</sup>

SBSSTC Ferozepur, Punjab, 152004, India

Received: 24 Sep. 2014, Revised: 17 Mar. 2015, Accepted: 19 Mar. 2015

Published online: 1 May 2015

**Abstract:** In this paper, the brief introduction of Fiber Bragg Grating, its significant applications, sensing principles, properties, fabrication and the basic designing of FBG have been discussed. FBG's are relatively simple to manufacture, small in dimension, low cost and exhibits good immunity from the electromagnetic radiations. The former inceptions and the essential techniques of fiber Bragg grating fabrication are described. This paper presents a comprehensive and systematic overview of FBG technology.

**Keywords:** Fiber Bragg grating, Current applications of Fiber Bragg Grating, Fiber Bragg Grating sensors.

## 1 Introduction

A Fiber Bragg Grating is revealing the core of SMF to a periodic model of passionate ultra violet light. The spotlight generates a stable increase in the refractive index of the core of fiber to produce a fixed index modulation in the direction of the exposure pattern and this fixed index modulation is known as grating. At each periodic refraction small amount of light is reflected. When the grating period is about half the input wavelength of light, all the reflected light signals merge comprehensively to one large reflection at a specific channel. This is known as the Bragg condition. The development of permanent grating in optical fiber was first introduced by Hill et al. in 1978 at Canadian communication research centre, Ottawa, Canada [1,2]. The FBG is depicted in Fig 1. By temperature and strain tuning of FBG, Spectral measurement is not done directly. A narrowband Bragg grating filter had been created over entire 1m length of fiber, known as Hill grating.

### 1.1 Formation of Grating and Fabrication Techniques

For use in fiber optic communication it was recognize that grating in an optical waveguide have numerous potential applications in the fabrication of devices and it was depicted that "Hill grating" could be used as a sensor for

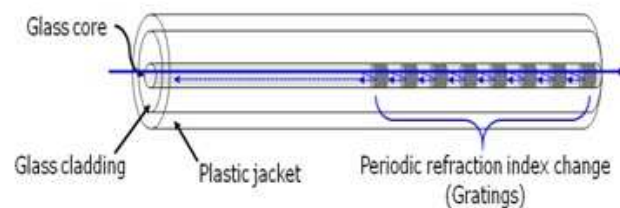

**Fig. 1:** Fiber Bragg grating in optical fiber[3]

strain by stretching fiber and as a feedback mirror for laser. The photosensitivity was overcome by Meltz et al. [3] who acknowledged from the work of Garside and Lam [4] that it was a two photon process, which could be made much more proficient if it was a one photon process at a wavelength in the 245 nm Germanium oxygen-vacancy defect bands [5]. The wavelength of the UV light is 244 nm that corresponds to one half of 488 nm, to generate the Hill gratings the wavelength of the blue argon laser line used [6]. In the core of the fiber, the two overlapping UV light beams interfere generating a periodic interference pattern that has equivalent periodic index grating. This technique is known as the transverse holographic technique. The two beam interferometer arrangement for side-writing FBG is shown in fig 2.

\* Corresponding author e-mail: [amitgrover\\_321@rediffmail.com](mailto:amitgrover_321@rediffmail.com)

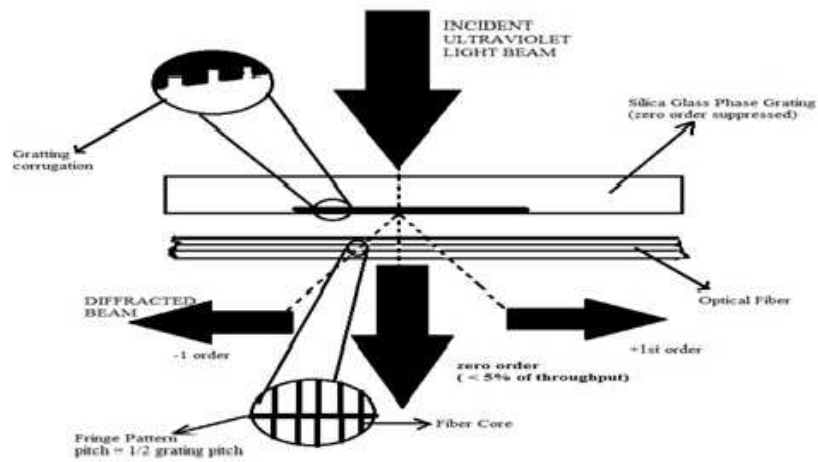

**Fig. 3:** Bragg grating fabrication apparatus based on a zero order null diffraction phase mask. The duty cycle of the phase mask is chosen to be 50% [7]

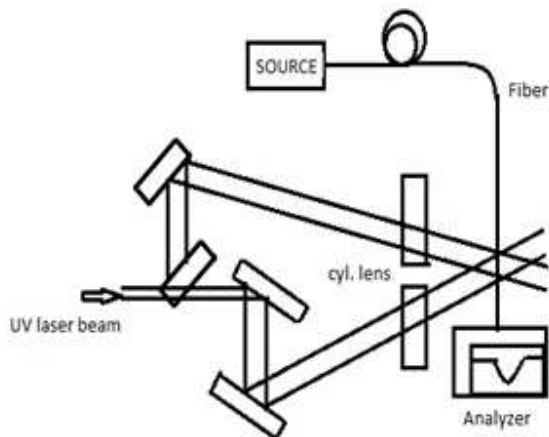

**Fig. 2:** Two-beam interferometer arrangement for Side-writing FBG [5]

The holographic technique for grating fabrication has two principle advantages. Bragg grating could be photo imprinted in the core of fiber without removing the glass cladding. Moreover, the period of the photo induced grating depends upon the angle between the two interfacing coherent ultraviolet light beams. Thus even through UV light is used to fabricate the grating, Bragg grating could be made to function at much longer wavelengths in a spectral region of interest for devices that have application in fiber optic communication and optical sensors [8].

Previously, FBG was first fabricating using the internal writing [1] and holographic technique [3]. These

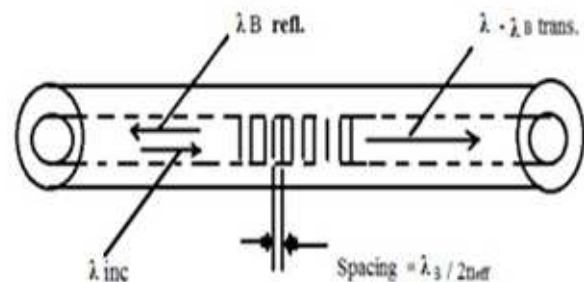

**Fig. 4:** Fiber Bragg for reflection of the incident mode at the  $\lambda$  [9]

methods have been superseded by the phase mask technique is prepared from flat slab of silica glass that is transparent to UV light [10]. The optical fiber is located in contact with corrugation of the phase as depicted in the figure no. 3 UV light that is incident normal to the phase mask passes via a periodic corrugation of the phase mask [7]. Generally, most of the deflected light is enclosed in the 0, +1 and -1 diffracted orders. Though, the phase mask is design by controlling the depth of the corrugation in the phase mask, to suppress the diffraction into the zero order. Experimentally in the zero-order the amount of light can be decreased to less than 5% with approximately 40% of the total light intensity divided equally in the 1 orders. The two 1 diffracted order beams interfere to produce a periodic pattern that photo imprints an equivalent grating in the optical fiber [8]. This period is independent of the wavelength of ultra violet light

irradiating the phase mask corrugation depth required to attain light is a function of the wavelength and the optical dispersion.

The phase mask method has the improvement of simplifying the manufacturing procedure for Bragg grating with a high performance. In contrast with the holographic system, the phase mask method provides easier alignment of the fiber for lower coherence requirements. The Bragg wavelength of the fiber will shift by 2nm. The phase mask technique is very flexible in that it can be used to fabricate gratings with controlled spectral response characteristics [11]. For example, the spectral response of finite length grating with a uniform index modulation along the fiber length has secondary maxima on both sides of the main reflection peak [12]. If the shape of the index modulation along the fiber length is given a bell-like functional shape, these secondary maxima can be suppressed this process is known as apodization [13]. Apodized fiber gratings have been fabricated using the phase masks techniques and suppressions of the side lobes of 30-40 db have been achieved [14,15]. The phase mask techniques have also been extended to the fabrication of apodized fiber grating. Aperiodic or chirped grating are desirable for making dispersion compensators [16]. Another approach to grating fabrication is the point-by-point technique [17]. In this method each index perturbation of the grating are written point-by-point. However, it has been used to fabricate micro-Bragg grating in optical fiber [18] but is most valuable for making coarse gratings with pitches of the order of 100m that are required LP modes converters and polarization mode converters [19]. Because of their use in long period fiber grating band-rejection filters and fiber amplifier gain equalizer the interest in coarse period grating has increased [20].

## 1.2 Fundamental Properties of Gratings

In the core of fiber, the index perturbation is a periodic structure identical to a volume hologram or a crystal lattice that act as a stop-band filter [8]. A narrow band of the incident optical field within the filter is reflected by successive, coherent scattering from the index variations [21,22]. Each reflection from a crest in the index perturbation is in phase with the next one at  $\lambda_B$ , as depicted in Fig.4 and any change in fiber properties like temperature, strain that varies the modal index or grating pitch will change the Bragg wavelength [9]. The grating filter characteristics can be understood and modeled by numerous approaches .

## 2 Current Applications of FBG

Fiber Bragg grating performs very important role in the optical fiber communication system. The possible use of FBG in communication system as shown in Fig. 5

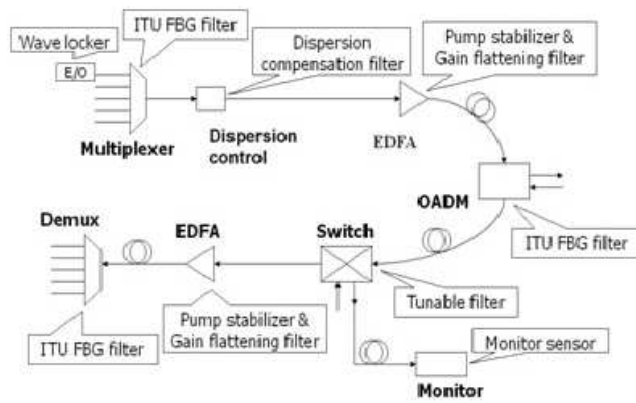

Fig. 5: FBG in OFC system

The recent applications of the FBG are:

- Fiber Bragg Grating for Dense WDM
- Fiber Bragg Grating for optical add drop multiplexer
- Fiber Bragg Grating as erbium-doped fiber amplifier Pump laser stabilizer
- Fiber Bragg Grating as Optical amplifier gain flattening filter

### 2.1 Fiber Bragg Grating for dense wavelength division multiplexing

To attain greater spectral efficiency value and total information capacity and to reduce the performance degradation caused by transmission impairments, the system investigation is of great importance. Therefore it is essential to calculate dense WDM transmission for broadband access. Furthermore it is important to evaluate Dense WDM direct system parameters with currently available and reasonable priced optical components [23]. The fiber Bragg grating technology performs vital role in DWDM system. With the help of the fiber Bragg grating we can filter out the particular wavelengths from the system as shown in the Fig. 6

### 2.2 FBG for OADM

An Optical add drop multiplexer is a device that used in WDM systems for multiplexing and routing different channels of light into or out of a SMF. This is a type of optical node, that is normally used for the production of optical telecommunications networks. Add/remove here refer to the ability of the device to add one or more new channels to an existing multi-wavelength WDM signal and to remove one or more channels, passing those signals to another path of network [24]. A traditional

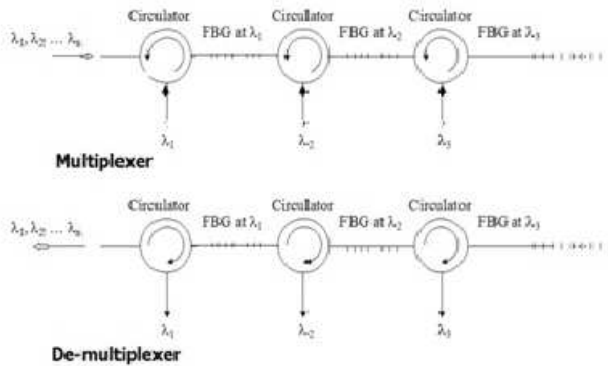

Fig. 6: FBG in DWDM system [23]

Optical Add/Drop Multiplexer comprises three stages such as an optical demultiplexer, an optical multiplexer and between them a method of reconfiguring the routes between the optical demultiplexer, the optical multiplexer and a set of ports for adding and removing signals. The demultiplexer separates wavelengths in an input fiber onto ports. The reconfiguration can be achieved by optical switches that direct the wavelengths to the optical multiplexer or to drop ports. The multiplexer multiplexes the wavelength that are to persist on from demultiplexer ports with those from the add ports, onto a single output fiber [25].

All the light paths that directly pass OADMs are termed cut-through light paths, while those that are added or removed at the optical add drop multiplexer node are named added/removed light paths. Physically, there are numerous ways to realize an optical add-drop multiplexer. There are a variety of demultiplexer and multiplexer technologies including thin film filters, fiber Bragg gratings with optical circulators, free space grating devices and integrated planar arrayed waveguide gratings. The switching or reconfiguration functions range from the manual fiber patch panel to a variety of switching technologies including microelectromechanical systems, liquid crystal and thermo-optic switches in planar waveguide circuits. The optical add drop multiplexer with the help FBG is depicted in Fig. 7

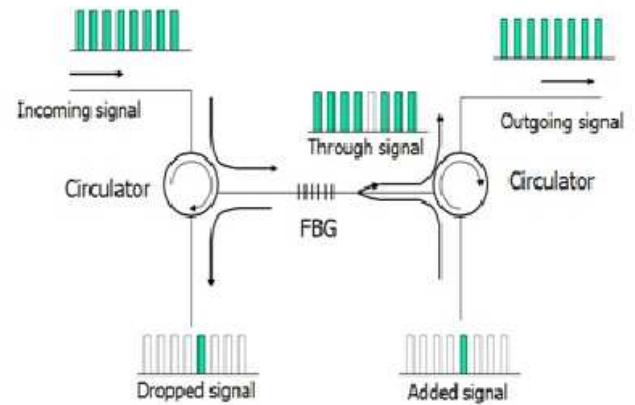

Fig. 7: OADM with the help of FBG[25]

manufacturing, this approach has proven to be practical and cost-effective [26].

The feedback from the Fiber Bragg Grating is efficient if the light reflected into the semiconductor laser cavity has the proper Transverse-electric polarization [27]. A change of the state of polarization upon propagation in the fiber can result in a loss of effective feedback [28]. The FBG-stabilized pump laser component is shown in Fig. 8.

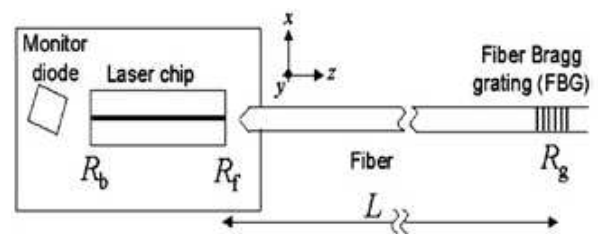

Fig. 8: Schematic of an FBG-stabilized pump laser module.  $R_b$ ,  $R_f$ , and  $R_g$  denote the back, front, and FBG power reflectivity[29]

### 2.3 FBG as EDFA Pump laser stabilizer

The properties of an EDFA depend on the characteristics of the pump laser diode. Today, FBGs are a standard passive component for wavelength and power stabilization of 980-nm pump lasers. The general technology for fiber Bragg grating stabilized pump laser modules is one that uses a standard SMF. In large-scale

The distance between laser chip and Fiber Bragg Grating is normally 0.5 to 2 m [30]. This is important for emerging 980-nm pump laser applications like uncoupled for one-for-two-replacement pump schemes in EDFAs with increasingly stringent requirements on performance, regarding power and wavelength stability [31].

### 2.4 FBG as optical amplifier gain flattening filter

EDFAs enabled the wide-ranging deployment of Dense Wavelength Division Multiplexing networks. Advancements in EDFA performance reduce have allowed for longer fiber links between regenerators. To the cost of regeneration efforts are ongoing to improve amplifier performance. For optical amplifiers, gain flatness is necessary to mitigate optical signal-to-noise and non-linear effects in Dense Wavelength Division Multiplexing networks. To equalize gain, an appropriate Gain flattening filter with a spectral response matching the inverse Gain profile is incorporated within the amplifier.

Among the technologies available for fixed gain flattening, the most widely employed are based on thin-film dielectrics and fiber grating. GFFs based on fiber gratings include chirped Bragg gratings, slanted Bragg gratings, and long-period gratings. GFFs have a significant impact on the level of gain ripple amplifier manufacturers can specify for their devices. The accumulation of gain ripple in a fiber optic link spanning many amplifiers will require regeneration of the optical signal periodically across the network. Signal regeneration imposes significant cost and complexities on the network. Proper selection of fixed GFFs can allow amplifier manufacturers to reduce gain ripple, thus offering significant economic benefits.

interference and transmission loss that make their usage challenging in many applications. Optical fiber sensing is the best solution to these challenges, using light as compare to electricity and standard optical fiber instead of copper wire [32]. The magnificent amount of innovation over the last two decades in the fiber-optic communication and optoelectronics industries has significantly reduced optical component prices and enhanced quality. The fiber-optic sensor works by modulating one or more properties of a propagating light wave, intensity, including phase, polarization and frequency in response to the environmental parameters to be measured. Intrinsic optical sensors utilize the optical fiber itself as the sensing element. The most commonly used optical sensors are the fiber Bragg grating that reflects a wavelength of light in response to variations in strain and temperature. FBGs are constructed by using a phase mask or holographic interference [33]. When a broad light beam is send to FBG, reflections from each segment of alternating refractive index interfere constructively only for a definite wavelength of light, known as Bragg wavelength, described in equation. This effectively causes the FBG to reflect a specific frequency of light while transmitting all others.

$$\lambda_b = 2n\Lambda \tag{1}$$

In equation (1),  $n$  is the effective refractive index of the core,  $\lambda_b$  is the Bragg wavelength, and  $\Lambda$  is the spacing between the fiber gratings, called the grating period. As shown in the Fig. 9

The Bragg wavelength is a function of the spacing between the gratings, Changes in temperature and strain affect both the grating period ( $\Lambda$ ) and effective refractive index ( $n$ ) of a Fiber Bragg Grating that results in a shift in the reflected wavelength [34]. The change of wavelength of Fiber Bragg Grating due to temperature and strain can be approximately described by equation (3).

Where  $\lambda_0$  is the initial wavelength and  $\Delta\lambda$  is the wavelength shift. This expression shows the impact of strain on the wavelength shift, where  $\rho_e$  is the strain-optic coefficient  $\Delta T$  is the temperature coefficient and  $\epsilon$  is the strain experienced by the grating. The second expression describes the impact of temperature on the wavelength shift, where  $\alpha_\Lambda$  is the thermal expansion coefficient and  $\alpha_n$  is the thermo-optic coefficient.  $\alpha_n$  Describes the change in refractive index while  $\alpha_\Lambda$  describes the expansion of the grating, both due to temperature. Because an FBG responds to both strain and temperature, you need to account for both effects and distinguish between the two. For sensing temperature, the FBG must remain unstrained. You can use packaged FBG temperature sensors to ensure the FBG inside the package is not coupled to any bending, tension, compression or torsion forces. The expansion coefficient  $\alpha_\Lambda$  of glass is practically negligible. Thus, changes in the reflected wavelength due to temperature can be primarily described by the change in the refractive index  $\alpha_n$  of the fiber. FBG

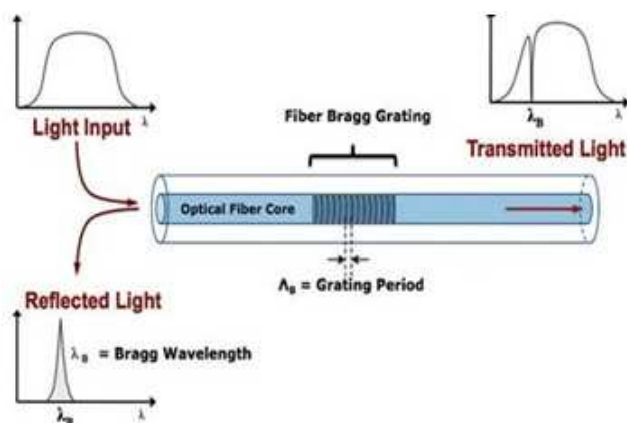

Fig. 9: Operation of the Fiber Bragg Grating sensor [32]

### 3 Fiber Bragg Grating Sensors

For decades, for measuring mechanical and physical phenomena electrical sensors have been used. These sensors have intrinsic borders like susceptibility to

strain sensors are more complex because both temperature and strain influence the sensor's reflected wavelength. For proper strain measurements, you must compensate for the temperature effects on the FBG. You can accomplish this by installing an FBG temperature sensor in close thermal contact with the FBG strain sensor. A simple subtraction of the FBG temperature sensor wavelength shift from the FBG strain sensor wavelength shift removes the second expression of equation (2), yielding a temperature compensated strain value.

The process of mounting an FBG strain gage is similar to mounting conventional electrical gages and FBG strain gages are available with a variety of form factors and mounting options including epoxy, weldable, bolt-on and embedded. The wavelength position conversion method is shown in fig. 11.

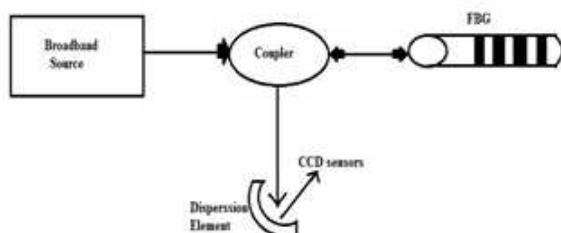

**Fig. 10:** Wavelength-Position Conversion Method of FBG Optical Sensors

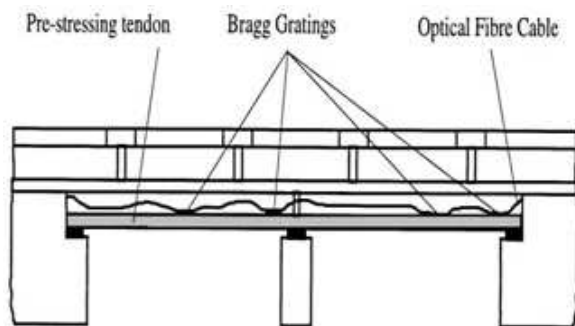

**Fig. 11:** FBG sensors for strain monitoring of a bridge[35]

This method can be fast, simultaneous measurements of all Fiber Bragg Grating in the array, but it offers limited SNR and resolution. The most important applications of the Fiber Bragg Grating sensors are:

## 4 Applications of FBG sensors:

### 4.1 FBG Sensors for Bridges

The highway bridge was first monitoring demonstrations for large structures that utilize carbon fiber-based composite pre-stressing tendons in the place of steel-based tendons to resolve the problem of corrosion [36]. In steel and concrete structures there is significant interest to monitor the deformation and strain for this composite materials are not well proven, so that fiber-optic sensing system are used. FBG sensors could be suitable for achieving such a goal. Though, if the Fiber Bragg Grating sensors can be rooted into the composite tendons through their fabrication shelter for the sensors and their leads would be provided[37]. A FBG temperature sensor was installed in the each girder to allow for correction of thermally induced strain. A four-channel demodulation system has been developed based on the Erbium-doped fiber laser and combination of the linear filter method. In this a length of Erbium-doped optical fiber is pumped with the help of semiconductor laser at 980 nm serves as the fiber laser whose wavelength can be tuned by the wavelength shift of the sensing and sensing FBG the FBG induced by strain change is detected by the linear filter that converts the wavelength shift into intensity change [35]. Two similar FBG sensor systems using a long-period fiber grating [38] and a chirped fiber grating as wavelength discriminating elements for demodulating the sensor output have been used for replacement of the bulk linear filter and have been field-tested for strain monitoring of concrete bridges recently [39]. The two approaches provide an all-fiber and robust design. In order to obtain more detailed information about the strain distribution in a bridge structure due to damage, an FBG sensor system with up to 60 FBGs has been embedded into a 14 scale bridge model by the Naval Research Laboratory in USA [37]. This system with a typical response time of 0.1 s is well suited for static strain mapping but not for dynamic strain measurement, due to the constraint of the scanning speed of the Fabry Perot tune able filter used for the wavelength-shift measurement.

This configuration combines FBGs with all-fiber Fabry Perot interferometric sensors. For a single sensor design, the phase change of the FFPI is used for high-sensitivity dynamic strain measurement whilst the wavelength shift of one of the two FBGs protected against strain are used for correction of thermal apparent strain. The wavelength deference between the two FBGs caused by a temperature gradient would be a problem for practical applications as it would degrade the visibility of the interferometric signal. Also, as the gauge length of the sensor is normally much less than the size of the structure to be monitored, the wavelength deference caused could be negligible due to small environmental temperature gradients between the two FBGs.

Static strain monitoring is simply obtained by directly measuring the wavelength shift of another FBG sensor that is arranged in tandem nearby the FFPI and has a different central wavelength to the FBGs in the FFPI, although it can also be achieved by the identification of the central fringe position of the interferometric signal when the FFPI is interrogated with a scanned local receiving interferometer [40]. This FFPI/FBG combination allows simultaneous measurement of three different parameters static strain, temperature and transient strain. Multiple FFPI/FBG sensor pairs are wavelength multiplexed for facilitating quasi-distributed measurement.

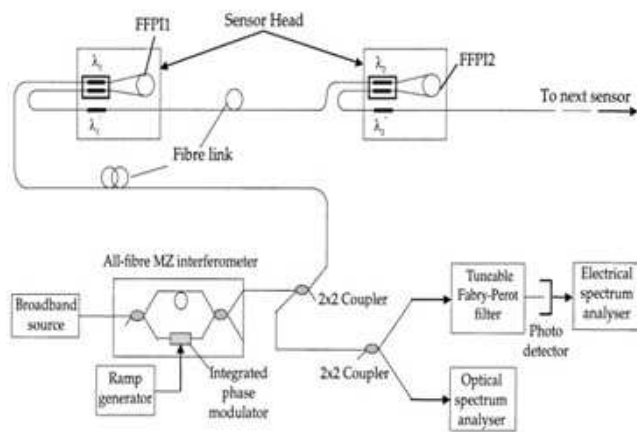

**Fig. 12:** Wavelength division multiplexed FBG/FFPI sensor system[41]

## 4.2 FBG Sensors for Mines

It is essential to monitor the displacement changes and measurement of load in underground excavations of mines and tunnels. Multiplexed Fiber Bragg Grating sensors can be able to replace the conventional electrical sensors like load cells and strain gauges that cannot be work on a simple multiplexed fashion and in a very risky environment with strong electro-magnetic interference generated by excavating machinery [42]. An Fiber Bragg Grating sensor system based on a Erbium-doped fiber source and a tune able Fabry Perot filter has been designed for long-term static displacement measurement in the roof of the mining excavations and in the hanging wall of the ore body's mineshaft [43,44]. A specially designed extensometer with a mechanical level mechanism can handle with the huge displacements of up to a few cm.

## 4.3 FBG sensors for Aircraft

Aerospace structures are normally used the Advanced materials for manufacturing engineering structures Compared with metallic materials, advanced composite materials can have higher fatigue resistance, lighter weight, higher strength-to-weight ratio, capability of obtaining complex shapes and no corrosion. Hence, to reduce the weight composite materials are used with FBG systems, maintenance cost of aircraft thus to improve in the performance [45]. Though, there is a important challenge is monitoring in service and realizing real-time health usage with an on-board sensor system. For such an application a distributed FBG sensor system is used [46]. Because FBG sensors are sensitive to temperature and strain, it is very essential to calculate the temperature and strain simultaneously to rectify the thermal strain and static strain measurement. Many approaches have been proposed for simultaneous measurement of temperature and strain [47]. A simple method to utilize an unstrained temperature reference Fiber Bragg Grating, but this is not appropriate for all cases, e.g. FBG sensors embedded in composites. This may due to three possibilities: (i) in a multiplexed system to achieve sufficient strain and temperature discrimination accuracy with the dual parameter method is required. (ii) To obtain high spatial resolution it is required to integrate both strain and temperature sensors into the same location.(iii) if the FBG is large it processing the distorted FBG signal. Local and accurate temperature compensation for static strain measurement with FBG sensors in composites is problem to be solved [48]. At this stage it is easier to calculate dynamic strain rather than static strain as temperature variations are normally much slower than dynamic strain changes and hence would not elect the measurement accuracy.

## 4.4 FBG sensors for the electric power industry

Due to the protection to electro-magnetic interference FBG sensors are superlative for utilize in the electrical power industry. In addition, FBGs can be used for long-distance distant operation is possible because of the low transmission loss in the fiber. Winding temperature of electrical power transformers, loading of power transmission lines and large electrical currents have been calculated with the Fiber Bragg Grating sensors [49].

## 4.5 Monitoring of power transmission lines

The mechanical load on power transmission lines, which may be occurred by heavy snow, e.g. in the hilly areas, there is no simple access for assessment. Thus, an on-line measurement system is required to monitor the altering load on the electrical power line. The load is converted

into strain by a metal plate which is attached to the line and onto which the Fiber Bragg Grating is bonded [50]. Many more sensors are required for such an application. Wavelength Division Multiplexing may no longer be able to handle with the significant increase in sensor. As the distance between adjoining Fiber Bragg Grating is large, high-speed modulation and demodulation would not be necessary.

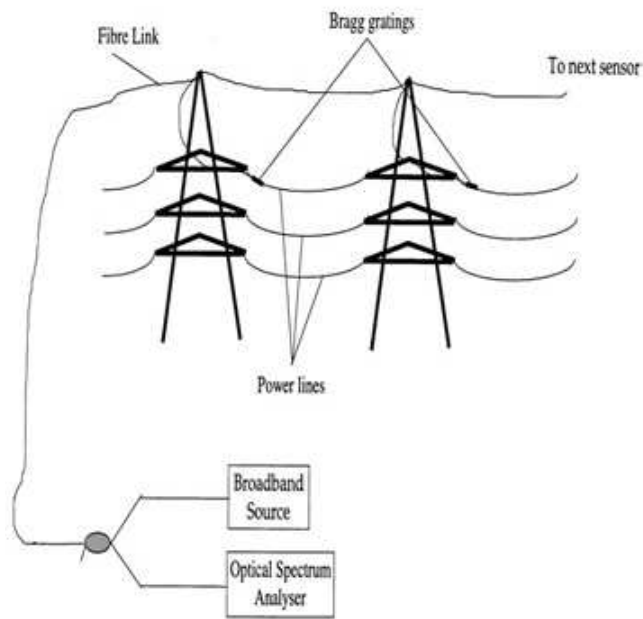

**Fig. 13:** Schematic diagram of FBG load monitoring system for power transmission lines [51]

#### 4.6 Winding temperature measurement

To understand the operation and verification of new or modified products, Knowledge of the local temperature distribution present in high-voltage, high power equipment like generators and transformers, is essential.

Defective or degraded equipment can be detected by continuously monitoring the variations in the winding temperature that reflects the performance of the cooling system. The FBG sensor has been demonstrated for such an application where the winding temperature of a high-voltage transformer is measured with two 1550 nm FBGs as sensing and reference elements interrogated via a standard optical spectrum analyzer [52].

#### 4.7 Temperature

A novel FBG temperature sensor system has been demonstrated, as shown in Fig. 14, in which high

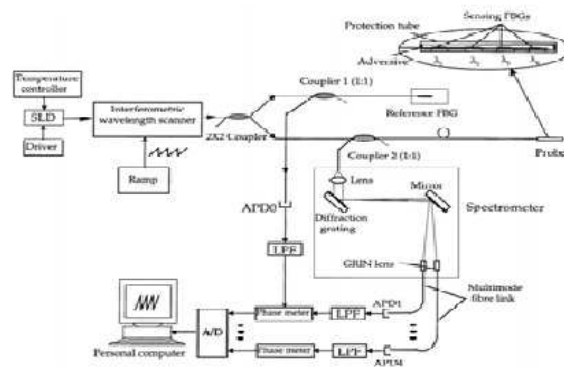

**Fig. 14:** Multi-channel FBG temperature sensor system. with super luminescent diode; avalanche photodiodes; low-pass filter; analogue-to-digital converter[53]

resolution detection of the wavelength-shifts induced by temperature changes are achieved using drift-compensated interferometric detection whereas the return signals from the FBG sensor array are demultiplexed with a simple monochromator [54]. A strain-free probe shown in the inset of Fig. 14 is designed by enclosing the Fiber Bragg Grating sensor array in a protection sleeve.

The internal diameter of the sleeve is small hence it can support large transverse stress without transferring it to the fiber. The inner diameter is selected to be a few times larger than the diameter of the fiber so that the inner surface of the sleeve does not contact the fiber under the maximum transverse stress condition [53]. The fiber link is connected to the processing unit via a fiber connector, making the probe disposable and interchangeable. A resolution of 0.13C and an accuracy of 0.23C over a temperature range of 30-603C have been achieved, that meet or exceed the requirements for many medical applications.

Another FBG temperature sensor system using a tunable Fabry Perot filter has been developed for achieving both WDM and wavelength-shift detection simultaneously, making the system simple and compact as depicted in Fig. 15 [55]. The performance of the probe with four sensing FBGs is tested by placing it in a container inside a NMR machine with a high magnetic field of 4.7 T.

With the help of thermal cross-talk between Fiber Bragg Grating the spatial resolution can be determined along to the connecting fiber. Due to the complexity of the specific heat transfer conditions it is not simple to verify the precise value of the resolution, although, experiments



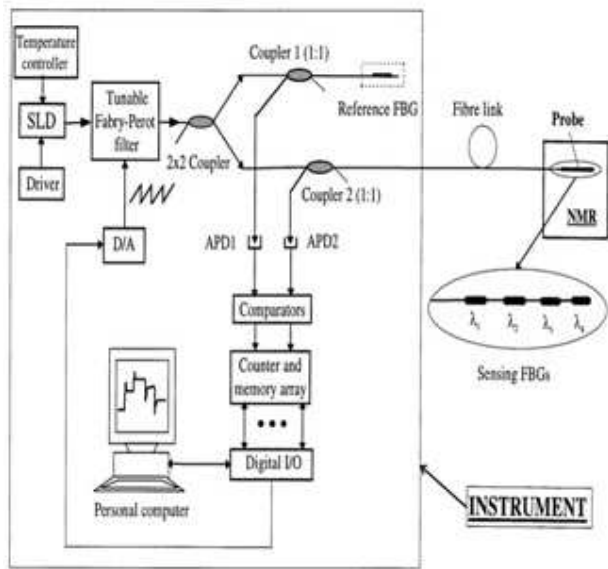

**Fig. 15:** FBG temperature sensor system with a FP tuneable Filter[55]

can be use for specified experimental conditions to measure the spatial resolution. The measurement of the heart's efficiency depends upon the low-directed thermo dilution catheter method; FBG sensor can also be used [55]. A low-directed thermo dilution catheter is inserted into the right atrium of the heart to be injected directly into the heart for measurement of the temperature of the blood in the pulmonary artery. Doctors can detect how much blood the heart pumps by temperature readings with pulse rate. This type of catheter with a FBG sensor has been demonstrated for replacement of a conventional catheter with a thermostat or a thermocouple [56].

## 5 Conclusion

Fiber Bragg Grating, its prospective applications and sensors are briefly reviewed. Presently, the most promising applications are in the fields of light wave communication and optical fiber sensors that are based on the existence of photosensitivity in silica optical fibers and optical waveguides. Recent growth in applications of the FBG sensor to large composite and concrete structures, in the electrical power industry and for Temperature sensing has been reviewed. Current applications have concentrated on the strain mapping of large composite and concrete structures and this may lead to the development of a major market for FBG sensors if cost-effective FBG multiplexing systems could become available. However, this technology could be extended to

other type of applications with invention of large photo sensitivity in different material system.

## References

- [1] Y. f. D. C. J. B.S. Kawasaki, K. O. Hill, Narrow-band bragg reflectors in optical fibers, *Opt. Letters* 3 (1978) 66–68.
- [2] W. g. G. Meltz, W.W. morey, Formation of bragg grating in optical fibers by a transverse holographic method, *Opt* 14 (1989) 823–825.
- [3] D. J. B. K. K.O. Hill, Y. Fujji, photosensitivity in optical fiber waveguides: application to reflected fiber fabrication, *Applied Physics Letters* 32 (1978) 647–649.
- [4] D. . W. lam, B. Garside, characterization of single mode fiber filter, *Applied Opt.* 20 (1981) 440–445.
- [5] V. garino cania, quelques propriétés optiques de i oxide de germanium vitreux dans i ultraviolet, oxide pur, *academie des sciences comptes rendus* 237 (1996) 291–317.
- [6] D. k. R. w. K. M. H. Hosono, Y. abe, H. kawazoe, nature and origin of the 5-ev band in sio2:geo2 glasses, *phys. Rev. b* 46 (1995) 2–445–2–451.
- [7] T. E. D.Z. Anderson, V. Mazrahi, A. white, Production of in fiber grating using diffractive optical element, *electron. Lett.* 29 (1993) 556–568.
- [8] K. o. Hill, G. Meltz, fiber bragg grating fundamentals and overview, *opt. lett.* 15 (8).
- [9] M. Yamada, K. Sakuda, Analysis of almost-periodic distributed feedback slab waveguides via a fundamental matrix approach, *appl. Opt.* 26 (1987) 3474–3478.
- [10] F. B. D. J. K. O. Hill, B. Malo, J. . Albert, Bragg grating fabrication in monomode photosensitive optical fiber by uv exposure through a phase mask, *appl. Phys. Lett.* 62 (1993) 1035–1037.
- [11] M. Matsuhara, K. Hill, optical waveguide band rejection filters: design, *appl. Opt.* 13 (1974) 2886–2888.
- [12] D. j. F. B. J. A. B.Malo, S. theriault, K. Hill, apodised in fiber bragg grating reflectors photoimprinted using a phase mask with, *Electron . lett.* 31 (1995) 223–224.
- [13] B. M. s. t. F. B. J. Albert, k. o. Hill, apodization of the spectral response of fiber bragg grating using a phase mask with variable diffraction efficiency, *electron. Lett.* 31 (1995) 222–223.
- [14] K. Hill, aperiodic distributed-parameter waveguides for integrated optics, *appl. Opt.* 13 (1974) 1853–1856.
- [15] K. A. V. F. B. D. J. K. O. Hill, B. Malo, I. Skinner, Efficient mode conversion in telecommunication fiber using externally written grating, *Electron. Lett.* 26 (1990) 1270–1272.
- [16] F. B. D. J. B.Malo, K. O. Hill, J. Albert, point by point fabrication of micro-bragg gratings in photosensitive fiber using single excimer pulse reflective index modification technique, *electron . lett.* 29 (1993) 1668–1669.
- [17] J. D. C. S. J. P. D. D. M. A. T.A. Strasser, P.J. chandonnet, D. Shenk, Uv induced fiber grating oadm devices for efficient bandwidth utilization, in: *tech. Dig. Optic Fiber Communication OFC96*, 1996.
- [18] J. J. V. B. T. A.M. Vengsarakar, P.J. Lemaire, J. Sipe, Long-period fiber gratings as band-rejection filters, in: *optic. Fiber Commun. OFC95*, San diego, CA, 1995.

- [19] A. K. O. M. A. P. V. P. E.M. Dianov, V.I. Karpov, S. Vasilev, Gain spectrum in photosensitivity and quadratic nonlinear in glass waveguides: fundamentals and applications, OSA tech. Dig. Series 22 (1995) 14–17.
- [20] J. J. P. J. L. N. B. A.M. Vengsarakar, J.R Pedrazzani, C. Davidson, long-period fiber grating-based gain equalizers, opt. lett. 21 (336-338) 1996.
- [21] H. Kogelnick, Filter response of nonuniform almost-periodic grating, Bell syst. Tech. j. 55 (1976) 109–126.
- [22] L. Waller-Brophy, D. Hall, Analysis of waveguide gratings: application of rouard method, J. opt.soc. Amer. a. 2 (1985) 863–871.
- [23] V.Mizrahi, J. sipe, optical properties of photosensitive fiber phase gratings, J. lightware technol. 11 (1993) 1513–1517.
- [24] J. c. E. peral, J. Marti, iterative solution to the gelfand-levitan-mar.enko equations and applications to synthesis of fiber gratings, IEEE j. quantum electron 32 (1996) 2048–2078.
- [25] D. C. J. K. O. Hill, Y. Fujii, B. S. Kawasaki, Photosensitivity in optical fiber waveguides: Application to reflection filter fabrication, Appl. Phys. Lett. 32 (10) (1978) 647–649.
- [26] T. E. C. R. Giles, V. Mizrahi, Simultaneous wavelength stabilization of 980-nm pump lasers, IEEE Photon. Technol. Lett. 6 (8) (1994) 907–909.
- [27] G. S. L. D. B. F.Ventrudo, G. A. Rogers, T.N.Demayo, Wavelength and intensity stabilisation of 980nm diode lasers coupled to fibre bragg gratings, Electron. Lett. 30 (25) (1994) 2147–2149.
- [28] S. M. T. Pliska, C. Harder, Power stabilisation of uncooled 980 nm pump laser modules from 10 to 100 degree celsius, Electron. Lett. 37 (1) (2001) 33–34.
- [29] B. S. N. M. S. M. T. P. J. M. S. P. S. A. H. P. A. F. B. Schmidt, N. Lichtenstein, C. Harder, Further development of high power pump laser diodes, in: SPIE Int. Symp. Inform. Technol. Commun, Orlando, FL, 2003.
- [30] M. R. O. M. K. S. H. Measures RM, Alavie AT, Bragg grating structural sensing system for bridge monitoring, in: SPIE 2294, Distributed and Multiplexed Fiber Optic Sensors IV, 53, 1994, pp. 23–28. doi:10.1117/12.187400.
- [31] A. T. M. R. T. G. R. S. T. A. Measures RM, Maaskant R, Fiber-optic bragg gratings for bridge monitoring for cement concrete composites, 1997, pp. 32–36.
- [32] S. Lee, S. Choi, Interpretation for dynamic strain signal using fbg sensor, Institute of Electronics Engineers of Korea 247 (1998) 79–83.
- [33] S. Lee, Technique for fiber bragg grid sensor, Machines and Materials (in Korean) 14 (4) (2002) 16–24.
- [34] S. S. C. Lan, Z. Zhou, J. Ou, Fbg based intelligent monitoring system of the tianjin yonghe bridge, in: Proceedings of SPIE, Vol. 16, 2008.
- [35] H. W. D. F. b. P. B. c. G.C. Kahandawa, J.A. Epaarachchi a, Use of fixed wavelength fibre-bragg grating (fbg) filters to capture time domain data from the distorted spectrum of an embedded fbg sensor to estimate strain with an artificial neural network, Sensors and Actuators 194 (2013) 1–7.
- [36] I. D. Glisic B, Fiberoptic methods for structural health Monitoring Chichester, JohnWiley and Sons Ltd., 2007.
- [37] M. H. A. Nazmi A. Mohammed, Taha A. Ali n, Evaluation and performance enhancement for accurate fbg temperature sensor measurement with different apodization profiles in single and quasi-distributed dwdm systems, optics and lasers in engineering 55 (2014) 22–34.
- [38] G. C. N. MattaF, BastianiniF, Measurement in steel bridge with fiber optic sensors validation through diagnostic load test perform, Vol. 8, 2008, pp. 94–98.
- [39] A. J. F. carlus Rodaigues, carlus Fleix, development of monitoring system based on fbg sensor applied to concrete bridge, Vol. 10, 2011, pp. 147–156.
- [40] C. Staveley, Smart scan Interrogators for fiber Bragg Grating sensors, Smart fibers, technical Datasheet 5.001.232.13 (2012).
- [41] M. Optics, Embeddable strain sensor os3610, technical data sheet (2012).
- [42] M. Q. a. Wang H.Y., Yao Y.H., A new mine safety monitoring system with high reliability, China application of electronic technology 14 (2011) 74–77.
- [43] M. C. Chen H.J., Research on human heartrate measurement based on fiber bragg grating sensor technology, laser & infrared 39 (12) (2009) 1317–1320.
- [44] Z. M. Zhou H.T., how to weave optical fiber grating temperature sensor into fabric, shanghai textile science & technology 38 (2010) 18–20.
- [45] P. G. Tosi D, Olivero M, Dynamic strain measurement system with fiber bragg gratings and noise mitigation techniques, Mesa Science Technology 20.
- [46] N. K. Jsago R, A high reading rate fiber bragg grating sensor system using a high-speed swept light source based on fiber vibrations, Mesa Science Technology 20 (3:034021) (2009) 5.
- [47] D. X. T. H. W. P. L. C. Fu HY, Liu HL, High-speed fiber bragg grating sensor interrogation using dispersion compensation fiber, Electron Lett. 44 (10:6189) (2008) 8.
- [48] S. A. Cugnoni J, Gmr T, Inverse method based on modal analysis for characterizing the constitutive properties of thick composite plates, Computer structure 19.
- [49] H.-I. L. K. W. Yong Chena, Li-juan Chena, Research on fbg sensor signal wavelength demodulation based on improve wavelet transform, Optik 124 (2013) 4802–4804.
- [50] A. Z. C.L.N Veiga, L.S. Encinas, Neural networks improving robustness on fiber bragg gratings interrogation systems under optical power variations, in: Proceedings of SPIE: The International Society for Optical Engineering, 2008.
- [51] H. D. F. G.C.Kahandawa, J.A. Epaarachchi, An investigation of spectral response of embedded fiber bragg grating (fbg) sensors in a hollow composite cylindrical beam under pure torsion and combined loading, in: ACAM 6, Perth, Australia, 2010.
- [52] A. A. P.A.M Lopes, H.M. Gomes, Reliability analysis of laminated composite structure using finite elements and neural networks, Composite structures (2010) 1603–1613.
- [53] S. P.-P. S. S. S. K. Kesavan, K. Ravisankar, Experimental studies on fiber optic sensors embedded in concrete, Measurement 23 (2010) 157–163.
- [54] H.-n. L. G. S. Liang Ren, Zi-guang Jia, Design and experimental study on fbg hoop-strain sensor in pipeline monitoring, Optical fiber technology 20 (2014) 15–23.
- [55] D. T.-H. T. M.H. Yau, T.H.T. Chan, Using fiber bragg grating (fbg) sensors for vertical displacement measurement of bridges, in: 14th Asia Pacific Vibration Conference, hongkong, 2011, pp. 288–297.
- [56] C. M. K.C. Chuang, H.T. Liao, Dynamic sensing performance of a point-wise fiber bragg grating

displacement measurement system integrated in an active structural control system, Vol. 11, 2012, pp. 1125–1132.



**Sanjeev Dewra** was born in Panagarh (West Bengal), India, on October 22, 1971. He received a B.E (Electronics & Telecomm.) degree from Mahatma Gandhi Missions College of engineering & technology, Marathwada University, Aurangabad (M.S) in 1993

and a M.E. degree from GNDEC, Ludhiana in 2002. He is Ph.D. degree from Thapar University, Patiala (Punjab). His field of interest is optical add drop multiplexer & optical cross connect for optical communication systems. He has published various research papers in international journals & conferences. Mr. Dewra is a life member of the Indian Society for Technical Education, Institution of Engineers (India). He has over 20 years of Education Experience. He served as lecturer in Saint Kabir Institute of Pharmaceutical & Technical Education, Fazilka from 1994 to 1998. He then joined Lala Lajpat Rai Institute of Engineering & Technology, Moga as a lecturer in 1999. In 2000, he joined Giani Zail Singh College of Engineering & Technology, Bathinda (Punjab) as Lecturer in the Department of Electronics and Communication Engineering and continued till 2003. In 2003, he joined as a Lecturer in the Electronics and Communication Engineering Department in Shaheed Bhagat Singh College of Engineering and Technology, Ferozepur (Punjab) & became a senior Lecturer in 2005. Presently he is working as an Assistant Professor & Head of ECE Department in the same college.



**Vikas** was born in Hoshiarpur, Punjab, India, on 16 Nov., 1991. HE obtained his Bachelor's degree in Electronics and Communication Engineering from GGSCMT, kharar, Punjab, India. He is currently an M.Tech scholar in Electronics and

Communication Engineering Department at Shaheed Bhagat Singh State Technical Campus Ferozepur, Punjab, India. His research mainly focuses on Optical Fiber Communication.



**Amit Grover** became a Member (M) of Association ISTE in 2006, a Senior Member (SM) of society SELCOME in September 2009, and a Project-In charge (PI) in august 2011 and in September 2012. The author place of birth is Ferozepur, Punjab, India on

27th, September 1980. The author received his M. Tech degree in Electronics and Communication Engineering from Punjab Technical University, Kapurthla, Punjab, India in 2008 and received his B. Tech degree in Electronics and Communication Engineering from Punjab Technical University, Kapurthala, Punjab, India in 2001. Currently, he is working as an Assistant Professor in Shaheed Bhagat Singh State Technical Campus, Ferozepur, Punjab, India. The author is a Reviewer of many Reputed International Journals. His area of interest includes signal processing, MIMO systems, Wireless mobile communication; high speed digital communications, 4G Wireless Communications and VLSI Design.