

Covering Relation of Lattice Valued Non-Deterministic Automaton

Namrata Kaushal^{1,*}, Madhu Tiwari² and C. L. Parihar³

¹Department of Engineering Mathematics, Indore Institute of Science and Technology, Indore-453331, MP, India

²Department of Mathematics, Government Girls Post Graduate College Ujjain, MP, India

³Indian Academy of Mathematics, 500- Pushpratan Park (Devguradiya) Indore-452016 MP, India

*Corresponding author e-mail: nams0053@gmail.com

Received: 15 Aug. 2014, Revised: 19 Nov. 2014, Accepted: 21 Nov. 2014

Published online: 1 Jan. 2015

Abstract:

A non-deterministic finite automaton is generalization of deterministic finite state automata. The concept of non-determinism plays an attractive role in the field of theory of computation and *L-VFA* defined on distributive lattices generalize some results of non-deterministic finite automaton, in this reference we have taken lattice-valued finite automata (*L-VFA*) defined on distributive lattices. Using these dynamic characterization properties of such *L-VFA* we discuss nature of accepted language by product of two *L-VFA*. Moreover covering relation of *L-VFA* by inter relationship of two types of products also will be presented.

Keywords: Lattice valued automaton, and lattice-value languages, covering relation.

1 Introduction

The automata-theoretic approach is a fundamental approach for modular verification, partial-order verification real time system, hybrid time systems, open system and infinite state systems also [8]. Automata based methods is a power full tool in academics as well as industries too. Automata based application has been playing imported roles in the field of computer science, physics, biology and many more. Class of finite automata one is deterministic and another is non-deterministic have been discussed by several researchers. Deterministic finite automaton means the automaton cannot be in more than one state at any given time and non-deterministic means it may be in several states at any given time. Due to Finite number of states in a finite state automaton, the system designed in such a way-that it remembers only the important things and forgets the unimportant things. M. Mohri shows the theoretical properties of a non-deterministic lattice automaton in [7]. Lattice automata exhibit interesting features from a theoretical point of view. The basis of our work is lattice automata on finite word, which assigned to each input -

word as a lattice element. A lattice automaton is based on the concept of fuzzy sets defined by Zadeh [2, 5]. Class of fuzzy automata was introduced by Wee in [9, 10]. The concept of a fuzzy automaton is generalization of the classical concept of a non-deterministic automaton. Fuzzy approach was applied on automata theory in the earlier age. The valid reason to study fuzzy automata is that, many languages are fuzzy by nature. A well known structure of membership values that has recently been used in the theory of fuzzy set [3,10]. It has been also proved that, lattice automata on distributive lattice is a special case of weighted automata [6,9].

2. Preliminaries

Throughout the paper we use terminology of [6]

[6]A lattice is a 6-tuple $l = (L, \leq, \wedge, \vee, 0, 1)$ where 0 and 1 are the least and largest elements of L, respectively, \leq is the partial ordering in L; and for any $a, b \in L$ $a \wedge b$, and $a \vee b$ stand for the greatest lower bound (or meet) and the least upper bound (or join) of a and b , respectively.

2.1 Finite Automata

An automaton is defined as a system where energy, material

and information are transformed, transmitted, and used for performing some function without direct participation of man.

2.2 l - Valued finite automaton

A lattice valued finite automata (l -VFA) is a 5-tuple $U = (Q, \Sigma, \delta, I, F)$, where:

- 1) $Q \rightarrow \{q_0, q_1, q_2 \dots \dots q_n\}$ Finite set of states
- 2) $\Sigma \rightarrow \{\sigma_1, \sigma_2, \sigma_3 \dots \dots \sigma_m\}$ Finite input alphabet
- 3) $\delta: Q \times \Sigma \times Q \rightarrow l$ Lattice valued transition relation
- 4) $I: Q \rightarrow l$ Lattice value subset of Q representing initial state
- 5) $F: Q \rightarrow l$ Lattice value subset of Q representing final state

The condition (3), (4) and (5) in the above definition represents the following propositions:

“ q is initial state” i.e $q \in I$ truth value given by $I(q)$.

“ q is terminal state” i.e $q \in F$ truth value given by $F(q)$.

“Input σ causes state q to become p according to specification given by” i.e $(q, \sigma, p) \in \delta$ truth value given by $\delta(q, \sigma, p)$.

2.3 Lattice valued recognizability

Lattice value recognizable predicate is a mapping from Set of string (Σ^*) over input alphabets to l i.e

6) $rec_U: \Sigma^* \rightarrow l$ Define as:

$$rec_U(\omega) = \bigvee \{ I(q_0) \wedge \delta(q_0, \sigma_1, q_1) \wedge \delta(q_1, \sigma_2, q_2) \wedge \dots \dots \dots \wedge \delta(q_{n-1}, \sigma_n, q_n) \wedge F(q_n) \}$$

And truth value of proposition that ω being accepted if – $rec_U(\omega) \in l$.

Set of all l -value languages over Σ^* is denoted by $l(\Sigma^*)$. Lattice value languages denoted by A, B, C .

2.4 Degree of recognized Language

If any language A is accepted by any automata U then its degree of acceptance will be number of lattice elements in its $rec_U(\omega)$ i.e $A = |U| \omega$ this is called degree of acceptance of l -valued language.

2.5 Extension of transition function (δ)

Extension of transition function gives two new propositions to automata which give new shape to the automata, which is defined as:

for all $p \in Q$

$$\delta^*(q, \varepsilon, p) = \begin{cases} 1 & \text{if } p = q \text{ where } \varepsilon \text{ is empty string} \\ 0 & \text{otherwise} \end{cases}$$

for all $\omega = \sigma_1, \sigma_2, \dots \sigma_n \in \Sigma^*$:

$$\delta^*(q, \sigma_1, \sigma_2, \dots \sigma_n, p) =$$

$$\bigvee \{ \delta(q_0, \sigma_1, q_1) \wedge \delta(q_1, \sigma_2, q_2) \wedge \dots \dots \dots \wedge \delta(q_{n-1}, \sigma_n, q_n) \}$$

$$q_1, q_2 \dots q_{n-1}, q_n \in Q$$

2.6 Condition of proposition for distributive lattice:

If for $a, b, c \in l$ lattice is distributive then extension of transition function satisfy following proposition:

$$\delta^*(q, \theta_1 \theta_2, p) = \bigvee_{r \in Q} [\delta^*(q, \theta_1, r) \wedge \delta(r, \theta_2, p)]$$

2.7 Restricted direct product of l -valued automata

Since $l(\Sigma^*)$ is closed under intersection operation so we can define direct product of two automata. Let $U_1 = (Q_1, \Sigma, \delta, I, F)$ and $U_2 = (Q_2, \Sigma, \eta, S, E)$ be two l -valued automaton then their direct product is:

$$U_1 \wedge U_2 = (Q_1 \times Q_2, \Sigma, \delta \wedge \eta, I \wedge S, F \wedge E)$$

Where $Q_1 \cap Q_2 = \phi$ and $Q_1 \times Q_2 = Q_1 \cup Q_2$.

$$I \wedge S: Q_1 \times Q_2 \rightarrow \begin{cases} I(p) & p \in Q_1 \\ S(q) & q \in Q_2 \end{cases}$$

$$\text{Define as } I \wedge S(p, q) = I(p) \wedge S(q); \forall p \in Q_1, q \in Q_2 \quad (I)$$

$$F \wedge E: Q_1 \times Q_2 \rightarrow \begin{cases} F(p) & p \in Q_1 \\ E(q) & q \in Q_2 \end{cases}$$

$$\text{Define as } F \wedge E(p, q) = F(p) \wedge E(q); \forall p \in Q_1, q \in Q_2 \quad (II)$$

$$\delta \wedge \eta: (Q_1 \times Q_2) \times \Sigma \times (Q_1 \times Q_2)$$

$$= \begin{cases} \delta(q_1, \sigma, p_1) & \text{if } p_1, q_1 \in Q_1 \\ \eta(q_2, \sigma, p_2) & \text{if } p_2, q_2 \in Q_2 \\ 1 & \text{if } p_1, p_2 \in Q_1 \text{ and if } q_1, q_2 \in Q_2 \end{cases}$$

$$\text{Define as } \delta \wedge \eta[(p_1, q_1), \sigma, (p_2, q_2)]$$

$$= \delta(q_1, \sigma, p_1) \wedge \eta(q_2, \sigma, p_2)$$

$$\forall p \in Q_1, q \in Q_2 \text{ and } \sigma \in \Sigma \quad (III)$$

2.8 Full direct product of l -valued automata

$U_1 = (Q_1, \Sigma_1, \delta, I, F)$ And $U_2 = (Q_2, \Sigma_2, \eta, S, E)$ be two l -valued automata then their direct product is:

$$U_1 \times U_2 = (Q_1 \times Q_2, \Sigma_1 \times \Sigma_2, \delta \times \eta, I \times S, F \times E)$$

Where $Q_1 \cap Q_2 = \phi$ and $Q_1 \times Q_2 = Q_1 \cup Q_2 = Q$

$$I \times S: Q_1 \times Q_2 \rightarrow \begin{cases} I(p) & p \in Q_1 \\ S(q) & q \in Q_2 \end{cases}$$

$$\text{Define as } I \times S(p, q) = I(p) \wedge S(q)$$

$\forall p \in Q_1, q \in Q_2(IV)$

$$F \times E: Q_1 \times Q_2 \rightarrow \begin{cases} F(p) & p \in Q_1 \\ E(q) & q \in Q_2 \end{cases}$$

Define as $F \times E(p, q) = F(p) \wedge E(q)$

$\forall p \in Q_1, q \in Q_2(V)$

$$\delta \times \eta: (Q_1 \times Q_2) \times (\Sigma_1 \times \Sigma_2) \times (Q_1 \times Q_2) = \begin{cases} \delta(q_1, \sigma_1, p_1) & \text{if } p_1, q_1 \in Q_1 \\ \eta(q_2, \sigma_2, p_2) & \text{if } p_2, q_2 \in Q_2 \\ a & \text{if } p_1, p_2 \in Q_1 \text{ and } q_1, q_2 \in Q_2 \\ 1 & \text{otherwise} \end{cases}$$

Where

$$a = \bigvee_{r_1 \in Q_1} [\delta(p, \sigma_1, r_1) \wedge F(r_1) \wedge S(q)] \wedge \bigvee_{r_2 \in Q_2} [\eta(r_2, \sigma_2, q) \wedge F(p) \wedge S(r_2)]$$

$$\delta \times \eta[(p_1, q_1), \sigma, (p_2, q_2)] = \delta(q_1, \sigma_1, p_1) \wedge \eta(q_2, \sigma_2, p_2)$$

$\forall p_1, q_1 \in Q_1, p_2, q_2 \in Q_2, \sigma_1 \in \Sigma_1 \& \sigma_2 \in \Sigma_2(VI)$

2.9 Covering relation of automata

For l -VFA $U_i = (Q_i, \Sigma_i, \delta_i, I_i, F_i)$ $i = 1, 2$ let $\phi: Q_2 \rightarrow Q_1$ and $\psi: \Sigma_2 \rightarrow \Sigma_1$ are two mapping then $(\phi, \psi): U_2 \rightarrow U_1$ called covering from U_2 to U_1 if for all $\sigma \in \Sigma$ following inequality holds:

$$\delta_1(\phi(q), \sigma, \phi(p)) \leq \delta_2(q, \sigma, p)$$

$$I_1(\phi(q)) \leq I_2(q) \quad \text{and}$$

$$F_1(\phi(q)) \leq F_2(q)$$

Example: l -Valued finite automaton

- 1) $Q \rightarrow \{q_0, q_1, q_2, q_3, q_4\}$ Finite set of states
- 2) $\Sigma \rightarrow \{0, 1\}$ Finite input alphabet
- 3) $\delta: Q \times \Sigma \times Q \rightarrow l$ Lattice valued transition relation.

Define as:

$$\delta(q_0, 0, q_1) = b, \delta(q_0, 0, q_2) = c$$

$$\delta(q_1, 1, q_1) = 1, \delta(q_2, 0, q_2) = 1$$

$$\delta(q_1, 0, q_3) = 1, \delta(q_2, 0, q_3) = 1$$

$$\delta(q_3, 0, q_4) = a, \delta(q_4, 0, q_4) = 1$$

$$\delta(q_4, 1, q_4) = 1$$

$l = \{0, 1, a, b, c, \leq\}$ Where:

$b < a$ and c can not be comparable with a and b .

4) $I: Q \rightarrow l$ Lattice value subset of Q representing initial state, $I = 1/q_0$

5) $F: Q \rightarrow l$ Lattice value subset of Q representing final state,

$F = 1/q_4$

By the calculation, we can see that for any $A \in l(\Sigma^*)$

$$\text{rec}_U(\omega) = (a \wedge b) \vee (a \wedge c) = b \text{ if } \omega \in 01^*00(0+1)^* \text{ and}$$

$$\text{rec}_U(\omega) = 0 \text{ in other cases.}$$

Defined automata are represented is figure given below:

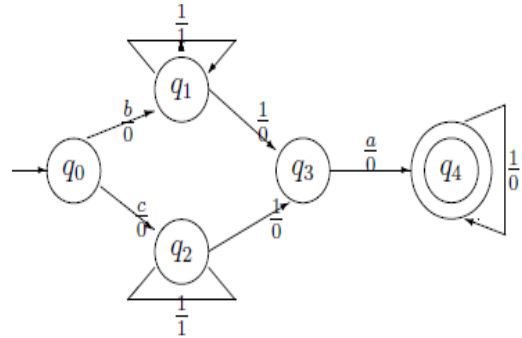

Fig. 1; l -Valued finite automaton

3. Main Theorem

If $U_1 = (Q_1, \Sigma, \delta, I, F)$ and $U_2 = (Q_2, \Sigma, \eta, S, E)$ is l -VFA and have same input and accepting A, B regular languages respectively and there are an automata $U_1 \wedge U_2 = (Q_1 \times Q_2, \Sigma, \delta \wedge \eta, I \wedge S, F \wedge E)$ which accept regular language $A \wedge B$, and if $U_1 = (Q_1, \Sigma_1, \delta, I, F)$ and $U_2 = (Q_2, \Sigma_2, \eta, S, E)$ be two l -VFA have different inputs and accepting A, B regular languages respectively and there are an automata $U_1 \times U_2 = (Q_1 \times Q_2, \Sigma_1 \times \Sigma_2, \delta \times \eta, I \times S, F \times E)$ which also accept regular language $A \wedge B$ then there must be an relation from Q_2 to Q_1 such that U_1 covers U_2 .

Proof: We will prove covering relation by inter relationship between two products of automata. For this let ϕ be an mapping define as:

$$\phi: Q_2 \rightarrow Q_1 \text{ And } \psi: \Sigma \rightarrow \Sigma_1 \times \Sigma_2 \text{ by } \psi(\sigma) = (\sigma_1 \sigma_2)$$

$$\delta \wedge \eta[\phi(p_1, q_1), \sigma, \phi(p_2, q_2)] = \delta \wedge \eta[(p_1, q_1), \psi(\sigma), (p_2, q_2)]$$

$$= \delta \wedge \eta[(p_1, q_1), \sigma_1 \sigma_2, (p_2, q_2)]$$

$$= \delta(p_1, \sigma_1, p_2) \wedge \eta(q_1, \sigma_2, q_2)$$

$$= \delta \times \eta[(p_1, q_1), \sigma, (p_2, q_2)]$$

.....(from VI)

Similarly: $I \wedge S(\phi(p_1, q_1)) = I \wedge S(p_1, q_1)$

$$= I(p_1) \wedge S(q_1)$$

$$= I \times S(p_1, q_1)$$

...(from IV)

Similarly: $F \wedge E(\phi(p_1, q_1)) = F \wedge E(p_1, q_1)$

$$= F(p_1) \wedge E(q_1)$$

$$= F \times E(p_1, q_1)$$

.....(from V)

From above properties we can write $U_1 \wedge U_2 \leq U_1 \times U_2$ hence (\emptyset, ψ) is covering from U_1 to U_2 .

3.1 Properties of covering relation

Covering relation of two l -VFA automaton satisfy reflexive and transitive properties.

Proof: $U_1 = (Q_1, \Sigma, \delta, I, F)$ and $U_2 = (Q_2, \Sigma, \eta, S, E)$ is l -VFA. Now define identity mapping $\emptyset: Q \rightarrow Q$ so that we have $Q_1 = Q_2, \delta = \eta, I = S, F = E$ and by definition of U_1 and U_2 having same input and output alphabets again we get same results, thus covering relation is reflexive.

Now to prove relation is transitive suppose U_3 covers U_2 and U_1 covers U_3

Where $U_1 = (Q_1, \Sigma, \delta, I, F)$ $U_2 = (Q_2, \Sigma, \eta, S, E)$ and $U_3 = (Q_3, \Sigma, \gamma, O, D)$ now U_3 covers U_2 imply that:

$S = O$ and $E = D$ and \exists a mapping $\beta: Q_2 \rightarrow Q_3$ such that:

$$1) \gamma(\beta(q), \sigma, \beta(p)) \leq \eta(q, \sigma, p)$$

$$2) O(\beta(q)) \leq S(q)$$

$$3) D(\beta(q)) \leq E(q)$$

Now if U_1 covers U_3 imply that $S = I$ and $E = F$ and \exists a mapping $\tau: Q_3 \rightarrow Q_1$ such that:

$$4) \delta(\tau(q), \sigma, \tau(p)) \leq \gamma(q, \sigma, p)$$

$$5) I(\tau(q)) \leq O(q)$$

$$6) F(\tau(q)) \leq D(q)$$

Now consider the mapping $\pi(\tau \circ \beta): Q_2 \rightarrow Q_1$

$$\delta(\pi(q), \sigma, \pi(p)) \leq \delta(\tau \circ \beta(q), \sigma, \tau \circ \beta(p)) \text{ (From equation 4)}$$

$$\leq \gamma(\beta(q), \sigma, \beta(p)) \text{ (From equation 1)}$$

$$\leq \eta(q, \sigma, p)$$

Which shows that covering relation is transitive.

3.2 Main Theorem

If l is distributive lattice and $U_1 = (Q_1, \Sigma, \delta, I, F)$ and $U_2 = (Q_2, \Sigma, \eta, S, E)$ be two l -VFA accepting A and B languages respectively then $A \wedge B$ will be accepted by $U_1 \wedge U_2$.

Proof: Let for $a, b, c \in l$ $a \wedge (b \vee c) = (a \wedge b) \vee (a \wedge c)$ by the definition of language acceptability if A is accepted by U_1 and B accepted by U_2 then there is an $\text{rec}_{U_1}(\omega)$ and $\text{rec}_{U_2}(\omega)$ such that $A = |U_1| = \text{rec}_{U_1}(\omega)$ and $B = |U_2| = \text{rec}_{U_2}(\omega)$ let $\omega = \sigma_1, \sigma_2, \dots, \sigma_n \in \Sigma^*$

$$(A \wedge B) \omega = |U_1| \omega \wedge |U_2| \omega$$

$$= \bigvee_{p_0, p_1, \dots, p_n \in Q_1} [I(p_0) \wedge \delta(p_0, \sigma_1, p_1) \wedge \dots \wedge \delta(p_{n-1}, \sigma_n, p_n) \wedge F(p_n)] \wedge$$

$$\bigvee_{q_0, q_1, \dots, q_n \in Q_2} [S(q_0) \wedge \delta(q_0, \sigma_1, q_1) \wedge \dots \wedge \delta(q_{n-1}, \sigma_n, q_n) \wedge E(q_n)]$$

$$= \bigvee_{p_0, p_1, \dots, p_n \in Q_1} \bigvee_{q_0, q_1, \dots, q_n \in Q_2} [I(p_0) \wedge S(q_0)] \wedge [F(p_n) \wedge E(q_n)] \wedge$$

$$[\delta(p_0, \sigma_1, p_1) \wedge \dots \wedge \delta(p_{n-1}, \sigma_n, p_n) \wedge \eta(q_0, \sigma_1, q_1) \wedge \dots$$

$$\dots \wedge \eta(q_{n-1}, \sigma_n, q_n)]$$

$$= \bigvee_{p_0, p_1, \dots, p_n \in Q_1} \bigvee_{q_0, q_1, \dots, q_n \in Q_2} [I(p_0) \wedge S(q_0)] \wedge [F(p_n) \wedge E(q_n)] \wedge$$

$$\delta(p_0, \sigma_1, p_1) \wedge \eta(q_0, \sigma_1, q_1) \dots \wedge \delta(p_{n-1}, \sigma_n, p_n) \wedge \eta(q_{n-1}, \sigma_n, q_n)]$$

$$= \bigvee_{(p_0, q_0), (p_1, q_1), \dots, (p_n, q_n) \in Q_1 \times Q_2} \{ [$$

$$I \wedge S(p_0, q_0)] \wedge [F \wedge E(p_n, q_n)] \wedge [\delta \wedge \eta((p_0, q_0), \sigma_1, (p_1, q_1)) \wedge$$

$$\dots \wedge \delta \wedge \eta((p_{n-1}, q_{n-1}), \sigma_n, (p_n, q_n))] \}$$

$$= |U_1 \wedge U_2| \omega$$

By above result we can conclude that there exist an automata $U_1 \wedge U_2$ accepting language $A \wedge B$.

4. Conclusion

An automaton is defined as a system where energy, material and information are transformed, transmitted and used for performing some functions without direct participation of man while covering gives a copy of an l -VFA having fewer states and equally powerful in computation, moreover covering relation is transitive as well as reflexive also hence presented result in this paper helps in theory of computation.

Acknowledgement

The first author acknowledges to editor of natural science publication for their cooperation and kind support. The authors are also grateful to the anonymous referee for a careful checking of the details and for helpful comments that improved this paper.

References

- [1] D.S. Malik, J.N. Mordeson, and M.K. Sen; "Minimization of fuzzy finite automata". Information Sciences (Elsevier) 113,323–330(1999).
- [2] E.T. Lee, L.A. Zadeh, "Note on fuzzy languages". Information Sciences 1, 421-434 (1969).
- [3] J. Ignjatovic, M. Ciric, S. Bogdanovic; "Determinization of fuzzy automata with membership values in complete resituated lattices". Information Sciences 178, 164–180 (2008).
- [4] J.N.Mordeson, D.S. Malik; "Fuzzy Automata and Languages: Theory and Applications". Chapman & Hall CRC, Boca Raton, London, (2002).
- [5] L. A. Zadeh; "Fuzzy Sets". Information and Control 8, 338–353 (1965).
- [6] Li. Yongming; "Finite automata theory with membership values in lattices". Information Sciences,181(5),1003-1017 (2011)
- [7] M. Mohri; "Finite-state transducers in language and speech processing". Computational Linguistics 23(2) 269–311 (1997).
- [8] O. Kupferman and Y. Lustig; "Lattice Automata". In VMCAI (Springer), 2007.
- [9] S. Eilenberg; "Automata Languages and Machines". Academic Press, New York, A,B (1974).
- [10] W. Kuich and A. Saloma; "Semi rings, Automata Languages". EATCS Monographs on Theoretical Computer Science, (1986).
- [11] Y. Li W. and Pedrycz; "Minimization of lattice finite automata and its application to the decomposition of lattice languages". Fuzzy Sets and Systems, 158(13), 1423–1436 (2007).
- [12] Y.M. Li, W. Pedrycz; "Fuzzy finite automata and fuzzy regular expressions with membership values in lattice-ordered monoids". Fuzzy Sets and Systems 156 68-92 (2005).