

Comparison of Intelligent Fuzzy Controller and Fuzzy Rule Suram Algorithms in the Drying Process

Zakarias Situmorang^{1,*} and Alice E. Husein²

¹Faculty of Computer Science, Universitas Katolik Santo Thomas, Medan, Indonesia

²Language Center, Universitas Katolik Santo Thomas, Medan, Indonesia

Received: 22 Feb. 2023, Revised: 2 May 2023, Accepted: 7 May 2023.

Published online: 1 Jun. 2023.

Abstract: Both the Intelligent Fuzzy Controller and Suram Fuzzy Rule are using a look-up table such as defuzzification analysis, which is based on weather variables, namely ambient temperature and ambient humidity for a drying process. State variable membership functions are expressed in terms of error values and error changes with typical triangular maps and trapezoidal maps. An Intelligent fuzzy controller is a hybrid controller which consists of an optimal fuzzy controller, fuzzy controller, and adaptive fuzzy controller. Membership function design is used to build the algorithm process. The algorithm process was developed based on the input-output knowledge pair for the drying process. The membership function must be stable and flexible with respect to weather and performance derived from the acquisition process, time constants, and system delays. The developed control system involves temperature control in different zones and ambient humidity. The system model was developed using a system identification scheme based on online input/output data and knowledge gathered through extensive testing. The knowledge base of fuzzy tuners is derived from drying schedules for certain wood specimens. The intelligent fuzzy control algorithm is used for scheduling the controller on various drying schedules. The results show that the proposed approach to overall control has great potential for performance improvement when applied to other industrial kilns. An intelligent fuzzy controller is also implemented, and its performance is compared with conventional controllers, it is more smooth, robust and controllable. On the other hand, the Suram fuzzy rule is an algorithm developed to control a drying system using diesel as an energy source by modifying the value of the fuzzy membership function [0.5,1]; and has been developed taking into account the wind speed in the drying process. The comparison results show that the Fuzzy Rule Suram is more efficient than the Intelligent Fuzzy Controller in terms of the use of electrical energy, by maximizing the use of solar energy.

Keywords: Intelligent Fuzzy Controller, Fuzzy Rule Suram, Look-up Table.

1 Introduction

The control variable of the drying process kiln is temperature and humidity as used as variables of a drying schedule. It's variable as well as with the moisture of content the material, and controlled by the heater, sprayer, and damper, for the goal of performance of maximized of energy to achieve effective process for a set point target. Intelligent fuzzy controllers used a hybrid controller, that includes an Optimal Fuzzy Controller (OFC), Fuzzy Controller (FC), and Adaptive Fuzzy Controller (AFC). Design of membership function used to construct an algorithm process. The algorithm was developed based on knowledge and input-output pairs, and it was implemented for a solar energy material drying process kiln. The membership function must be stable high and flexible for weather and performance derived from the gain process, time constant, and time delay of the system. The developed control system involves the control of temperature at different zones, of ambient humidity, and ambient temperature. The system model is developed using a system identification scheme based on the online input/output data and knowledge accumulated through extensive tests. The knowledge base of the fuzzy tuner is derived from the drying schedule for a specific material.

The processing system of a solar energy wood dry kiln is a multi-input and a multi output system (MIMO) [1]. The variable inputs are energy from collector solar and/or heater, humidifying by the sprayer, and exchanging air by damper. The variable outputs are temperature and humidity of chamber. And the paper goals of controller are:

1. Design of prototype a solar energy wood dry kiln, and measurement of step the response of variable output and the reasoning the data used of design of membership function [2].

*Corresponding author e-mail: zakarias65@yahoo.com

2. The modelling of system MIMO of a solar energy wood dry kiln with state space and the gain feedback optimal K based of index performance the maximized of energy use and the time constant is minimum, and as used Lyapunov stability criterion. The optimal fuzzy controller of simplified the used for the scheduling of a gain control of model multi system from wood drying process kiln in steady state [2].
3. Design of the membership function of rule suram based of fuzzy logic with variables of weather is temperature ambient and conditions of air is humidity ambient, it implemented for the wood drying process. The membership function of the variable of the state is represented in error value and change error with typical of triangle and trapezium map of fuzzy controller [3].
4. The fuzzy adaptive controller design incorporates an adaptive control-based schedule of drying under conditions where the temperature of the chamber is constant but changes for the humidity of the chamber [4].

The algorithm of the intelligent fuzzy controller is used to scheduling of controllers, as the schedule of drying. Implemented algorithm at the source of code for the microcontroller.[5].

The Fuzzy Rule Suram Algorithm has been implemented in a solar material drying system using weather variables and environmental conditions variables [1]. But for the extended Fuzzy Rule Suram algorithm, the two variables are added by paying attention to wind speed. Some of the reasons for the need for this speed variable is that the wind speed greatly affects the percentage of the amount of energy captured by the collector. The drying rate increases with the increase in temperature and air velocity because the volume of air molecules expands at high temperatures so that the air capacity to absorb water vapor increases. The drying rate becomes saturated at a constant temperature and air velocity when the water content in the object is low. Process conditions the most effective drying on the dryer made is at a temperature of 128°C and wind speed of 2.8 m/s with a drying rate of 25 gr/hour on objects with a thickness of 2 cm and 45 gr/hour on objects with a thickness of 4 cm and effect on the drying process at high air velocity conditions ($v=2.8\text{m/s}$).

The wind speed at a certain level of drying of the material when the drying process begins, the material with high moisture content requires a high wind speed as well. Thus, a large number of water molecules have only a short distance to travel (diffusion) to reach the surface. Water is basically waiting for the air to transfer energy to the coffee (to evaporate the water) and then carry the moisture away. When coffee has a low water content, the amount of water on the surface is much less and the water molecules in the core have to travel further to reach the surface. Diffusion of water to the surface is slow, if there is no wind flow.

The coffee drying process uses a drying schedule that is very dependent on the moisture content of the coffee, by conditioning the kiln at room temperature and humidity. The control algorithm used to control the actuator is the heater, damper, and sprayer. Each running drying process aims to optimize processing time and available energy, under conditions of process stability. The main energy source is solar energy from the collector and an alternative energy source is electric heating [2]

The maximum utilization of solar energy in the coffee drying process is the goal of this control algorithm and depends on the amount of solar energy and changes in ambient temperature and wind speed. Response to changes in solar energy in environmental temperature and humidity variables is a control system variable. The coffee drying process begins by determining the set point value for the drying room temperature and humidity. The temperature and humidity conditions in the drying room are adjusted to the moisture content of the coffee.

This air-drying method of coffee is known as natural or unwashed coffee and is a traditional and ancient method. After the coffee is harvested, the coffee cherries are separated from the dirt by winnowing, and then placed on the flat surface of the dryer. If without a dryer, the drying process lasts 2-3 weeks, where the cherries are rotated 3 times a day, but with this dryer, 1 week is enough and after that do the stripping until the remaining coffee beans only [3][4][5].

The fuzzy rule suram algorithm is implemented for the drying scheduling of Arabia coffee by modifying the triangular and trapezoidal membership functions in the range. The wind speed is based on the input of solar energy collected by the collector. This process is fully controlled automatically continuously, so that the coffee drying process can be done quickly by maximizing the use of solar energy [6][7][8].

Prototype of Coffee Dry Kiln

The control parameters of this solar coffee drying system are the amount of load, duration, operating temperature and usually fixed air flow, although this can vary according to the moisture content of the coffee. Many mechanical drying systems, particularly horizontal designs, only dry efficiently when fully charged, others are more flexible. For this tool the coffee is placed in layers according to the air flow on a flat plate. Typical drying times are from 12 to 24 hours depending on input moisture content, technology and operating temperature [9][10][11][12][13][14][15][16][17].

If the duration is insufficient, the coffee product will not be stable and if it is too long, the producer loses money due to

loss of quality and weight. The uniformity of drying is an aspect that has received little attention but there is no reason to believe that rapid drying will result in a uniform population of dry particles because the migration of water through the seed and fruit tissues is quite slow. Air temperature is usually controlled at the inlet and is very important because temperatures in the grain above 45°C can damage the quality of the coffee and some of the immature beans will turn black and thus lose much of their commercial value. But at the beginning of the process, the temperature can reach 60°C with coffee water content above 32%. The prototype of coffee dry kiln at show of figure 1.

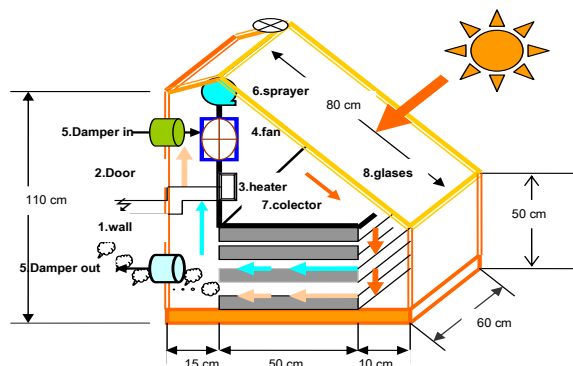

Fig. 1: Detail of design the prototyping of coffee drying kiln [1]

Measurement of solar energy by Pyranometer type MS-801 Chino, it has maximum voltage +50 mVDC, which to have a data from Agency of Meteorology and Geophysics Medan Indonesia. The most important part of this solar dryer is the heat circulation pump. The air in the kiln passes through the coffee load and absorbs moisture from the coffee. Part of that air circulates through a fan where the moisture is condensed and removed from the drying chamber. Thus, the heated dry air returns to the kiln chamber. Energy consumption is minimal, as there is almost no air exchange in/out. The air circulation in the kiln is very slow to lift the water content of the coffee. The solar coffee dryer control system considers that:

- a. Coffee does not need to be weeded every day but needs to be stirred daily.
- b. Also protected from contamination of the product by pets.
- c. Protected from rain during the day.
- d. Maintain different lot separations.
- e. Humidity monitoring is well controlled.

The type of collector used is a flat plate collector and the collector is oriented in such a way as to receive maximum solar energy, and functions as the roof of the coffee dryer.

The coffee drying schedule is a set of instructions for operating the kiln during the drying period presented in tabular form showing the temperatures and humidity to be used at various stages of the process. This schedule varies greatly depending on the solar energy collected by the collector. Similarly, the captured solar energy is highly dependent on wind speed, which is represented by air temperature and humidity. This coffee drying schedule is shown in Figure 2.

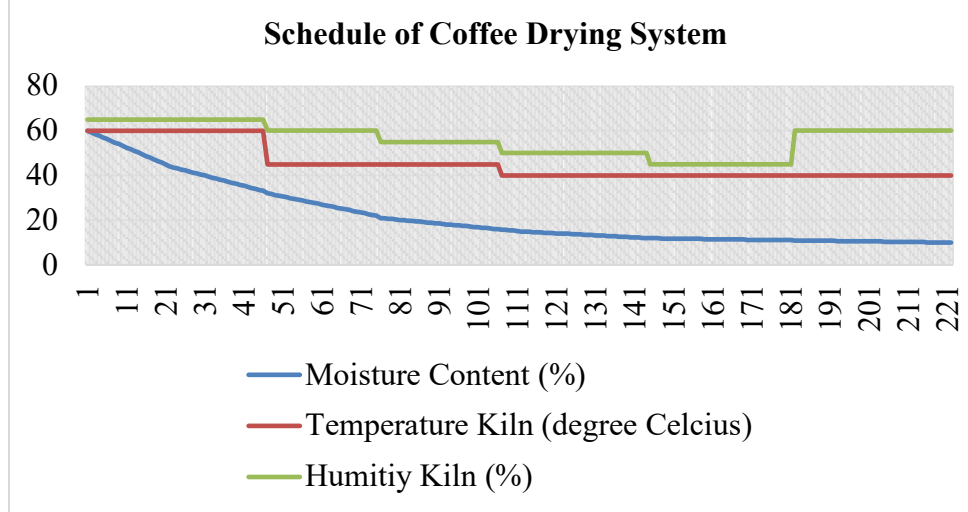

Fig. 2: Schedule of Coffee Drying System

2 Methodologies

The coffee drying process begins with filling the coffee holder plate from the prototype so that it reaches 100 kg, which is divided into 5 levels. According to experience with daily coffee drying, the drying schedule in Figure 2 is set according to the temperature and humidity in the kiln. The solar energy captured by the collector is flowed throughout the room through the coffee pile using a fan slowly. The dry air that flows in heats the coffee so that the water vapor in the coffee will be carried away by the hot air and flowed into the exhaust air. In order to minimize energy consumption, the damper is opened once in a while when the air is saturated, where the drying kiln has almost no internal/external air exchange [18][19][20].

The amount of solar energy collected by the collector is converted by the parameters of ambient temperature and ambient humidity according to the prevailing wind speed, as shown in table 1, and table 2. The amount of solar energy needed, for $MC \geq 22\%$ according to equation 1, and the amount solar energy needed, for $MC < 22\%$ according to equation 2.

$$I_0 = 617 + 9,7(Td_0 - 45) \text{ (watt/m}^2\text{)} \quad (1)$$

$$I_0 = 535 + 16.5(Td_0 - 40) \text{ (watt/m}^2\text{)} \quad (2)$$

Table 1: Convert solar radiation to variable temp. ambient and humidity ambient with wind speed $\geq 2,8$ m/s (high)

No.	Set Point Td ₀ (°C)	Set Point Hd ₀ (%)	MC (%)	Solar Radiation I ₀ (Watt/m ²)	Temp. Ambient Ta(°C)			Hum. Ambient Ha (°C)		
					Min	Rate	Max	Min	Rate	Max
1	2	3	4	6	7	8	9	10	11	12
1	60	65	45 - 60	763.0	30.5	31.5	32.5	54	62	70
2	60	65	33 - 45							
3	45	60	22 - 33	652.0	29.7	30.7	31.7	52	60	68
4	45	55	16 - 22	617.5	29.4	30.4	31.4	50	58	66
5	45	45	12 - 16	561.0	29.1	30.1	31.1	46	54	62
6	40	60	10 - 12	535.0	28.9	29.9	30.9	52	60	68

Table 2: Convert solar radiation to variable temp. ambient and humidity ambient with wind speed $< 2,8$ m/s (low)

No.	Set Point Td ₀ (°C)	Set Point Hd ₀ (%)	MC (%)	Solar Radiation I ₀ (Watt/m ²)	Temp. Ambient Ta(°C)			Hum. Ambient Ha (°C)		
					Min	Rate	Max	Min	Rate	Max
1	2	3	4	6	7	8	9	10	11	12
1	60	65	45 - 60	663.0	30.5	31.5	32.5	54	62	70
2	60	65	33 - 45							
3	45	60	22 - 33	552.0	29.7	30.7	31.7	52	60	68
4	45	55	16 - 22	517.5	29.4	30.4	31.4	50	58	66
5	45	45	12 - 16	461.0	29.1	30.1	31.1	46	54	62

6	40	60	10 - 12	435.0	28.9	29.9	30.9	52	60	68
---	----	----	---------	-------	------	------	------	----	----	----

The amount of solar energy needed, for $MC < 22\%$ according to equation 3, and the amount of solar energy needed, for $MC < 22\%$ according to equation 4.

$$I_0 = 517 + 9,0(Td_0 - 45) \text{ (watt/m}^2\text{)} \tag{3}$$

$$I_0 = 435 + 16,0(Td_0 - 40) \text{ (watt/m}^2\text{)} \tag{4}$$

The design of membership functions for the parameters in fuzzy logic is implemented in a triangular and trapezoidal membership function model according to the coffee drying schedule as shown in Figure 3. For this reason, it is necessary to apply a coffee-drying furnace control system. The process of fuzzification of membership functions in the range [0,5, 1], and for the weather, which is presented at ambient temperature T_a and changes in ambient temperature CT_a with a set point value of drying temperature $Td_0 = 60^\circ\text{C}$ and drying humidity $Rd_0 = 65\%$ is presented in Figure 4. with variable M: over - cloudy; B: cloudy; CB: clear clouds; C: clear; SC: clearest most obvious and for changes in ambient temperature used -H = - High, -M = -Medium, -S = - Small, Z = Zero, S = Small, M = Medium, H = High.

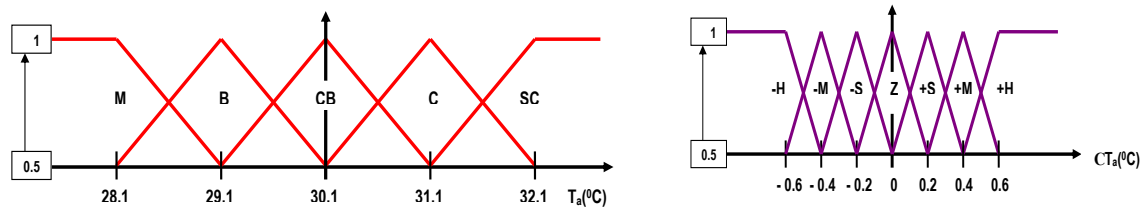

Fig. 3: Membership function of temperature ambient and change temperature ambient for $Td_0 = 60^\circ\text{C}$ and $Rd_0 = 65\%$

The computational process of changing ambient temperature parameters is expressed by equation.5. with $n = 0 \text{ s/d} \infty$

$$CT_a [(n+1)T] = T_a[(n+1)T] - T_a[nT] \tag{5}$$

Weather representation is also expressed in the environmental temperature variable and its changes and is used to maximize and calculate the value of the membership function, with reference to table 2. Fuzzification of the membership function in the range [0,5, 1] air conditions (ambient H_a humidity and changes in ambient humidity CH_a for set point drying temperature ($Td_0 = 60^\circ\text{C}$) and drying humidity ($Rd_0 = 65\%$) are presented in Figure 4. with variables: P: Hot; AP: Slightly Hot; H: Flock; S: Fresh; D: Cold, and for change in ambient humidity used -H = - High, -M = -Medium, -S = - Small, Z = Zero, S = Small, M = Medium, H = High.

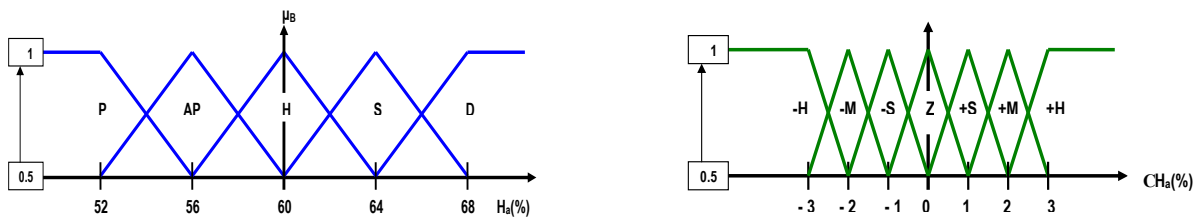

Fig. 4: Membership Function of humidity ambient and change humidity for $Td_0 = 60^\circ\text{C}$ and $Rd_0 = 65\%$

Computation process of variable change of humidity ambient are given eq.6. with $n \rightarrow 0 \text{ to } \sim$

$$CH_a [(n+1)T] = H_a[(n+1)T] - H_a[nT] \tag{6}$$

Representing air conditions in ambient humidity parameters and their changes used for the maximum membership function, with the appropriate rules in the look-up table schema, are shown in table 3. The next step is to adjust to table 1. and adjust to the drying schedule in figure 2.

Table 3: Look-up table for membership Function for temperature of ambient

$CT_a \backslash T_a$	Over-cloudy (M)	Cloudy (B)	Bright-Cloud (CB)	Clear (C)	Clearest (SC)
-H	Over-cloudy	Over-cloudy	Cloudy	Bright-Cloud	Clear
-M	Over-cloudy	Cloudy	Bright-Cloud	Clear	Clearest
-S	Over-cloudy	Cloudy	Bright-Cloud	Clear	Clearest

Z	Over-cloudy	Cloudy	Bright-Cloud	Clear	Clearest
+S	Over-cloudy	Cloudy	Bright-Cloud	Clear	Clearest
+M	Over-cloudy	Cloudy	Bright-Cloud	Clear	Clearest
+H	Cloudy	Bright-Cloud	Clear	Clearest	Clearest

Table 4: Look-up table for membership Function for humidity of ambient

H_a	Hot	Rather-Hots	Swarm	Fresh	Cold
-H	Hot	Hot	Rather-Hot	Swarm	Cold
-M	Hot	Rather-Hot	Swarm	Fresh	Cold
-S	Hot	Rather-Hot	Swarm	Fresh	Cold
Z	Hot	Rather-Hot	Swarm	Fresh	Cold
+S	Hot	Rather-Hot	Swarm	Fresh	Cold
+M	Hot	Rather-Hot	Swarm	Fresh	Cold
+H	Rather-Hot	Swarm	Fresh	Cold	Cold

3 Results

Intelligent fuzzy controller is used a hybrid controller included optimal fuzzy controller (OFC), fuzzy controller (FC), and adaptive fuzzy controller (AFC). The Schedule drying is a cycle of drying and have the different level of process [6]. A process doing at temperature and humidity variable are constant at set point any time. Intelligent fuzzy controller doing by rule of used controller at table 5.

Table 5: Rule of Used Controller.

IF temperature is ...	AND Humidity is ...	Then Controller is
constant	constant	<i>Fuzzy Controller (FC)</i>
constant	changes	<i>Adaptif Fuzzy Controller (AFC)</i>
changes	constant	<i>Optimal Fuzzy Controller (OFC)</i>
changes	changes	<i>Optimal Fuzzy Controller (OFC)</i>

The schematic of intelligent coordinator of intelligent fuzzy controller represented in figure 5, with algorithm the controller.

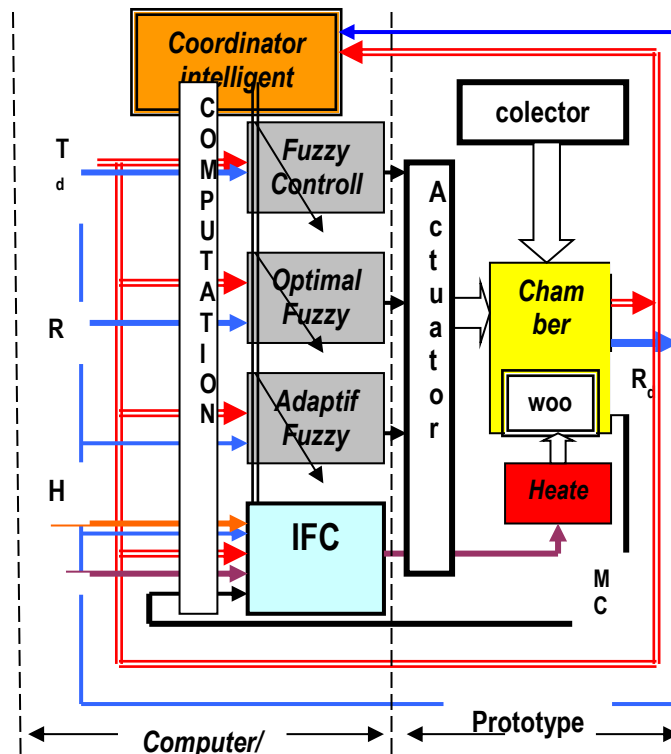

Fig. 5: Schematic of *Intelligent Fuzzy Controller* a Solar Energy Dry Kiln

Fuzzy Controller

A drying schedule is a set of directions for the operation of a kiln during the drying period and is usually presented in the form of tables showing the temperatures and humidity to be used at various stages of the process. These schedules vary with species, size and grade of timber being dried; they are also influenced by local production and selling practices, by the degree of care in kiln operation and in kiln characteristics" Schedule Drying for Coffee is shown in figure 2.

Rule suram based of fuzzy logic with variables of weather is temperature ambient and conditions of air is humidity ambient, it implemented for the Coffee drying process. The membership function of variable of state represented in error value and change error with typical of triangle and trapezium map. Result of Analysis to reach 8 fuzzy rule to control the output system can be constructed in a number of conditions of weather and conditions of air. It was used to minimize the consumption of electric energy from the heaters. The rule suram used to the stability and equilibrium of schedule of drying in chamber by the control of temperature and humidity. The result of implemented of fuzzy rule suram with the modification of membership function in range [0.5, 1] represented approximate to conditions riel. The 8 rules of suram to control the heater on OFC based of weather and conditions of air. Input variable in measurement by SHT11-sensor illustrated at table 6 and output variable used fuzzy rule suram shown at table 7. Block diagram of fuzzy controller illustrated at figure 6.

Table 6: Input Variable

No.	Variable	Range	Describe
1.	Temperature Drying Td	0 – 150 °C	Weather
2.	Temperature Ambient Ta	0 – 150 °C	
3.	Humidity Drying Rd	0 – 100 %	Conditions of air
4.	Humidity Ambient Ha	0 – 100 %	

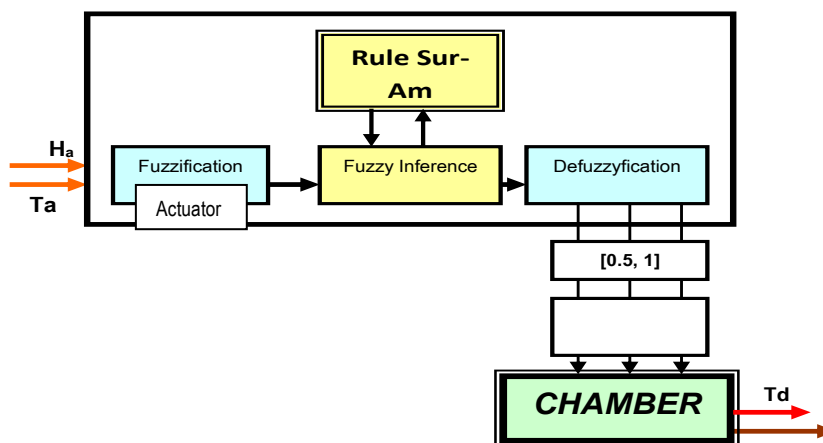

Fig. 6: Block diagram Fuzzy Controller

Table 7: Output Variable and Implemented the Fuzzy Rule Suram

No	Rule	Actuator			Conditions
		Heater	Damper	Sprayer	
1.	SUR-AM-1	off	off	S	To drop of Temperature Drying Td and to hoist of Humidity Drying Rd by very suddenly [Heating- Process]
2.	SUR-AM-2	H	off	Off	To hoist of Temperature Drying by very suddenly and to drop of humidity drying Rd.
3.	SUR-AM-3	H	D ₃	Off	To hoist of Temperature Drying Td and to stay of Humidity Drying Rd.
4.	SUR-AM-4	H	D ₂	S	To hoist of Temperature Drying and to drop of humidity drying Rd.
5.	SUR-AM-5	H ₁	D ₃	Off	To drop of Temperature Drying Td and to stay of Humidity Drying Rd
6.	SUR-AM-6	H ₂	off	S	To drop of Temperature Drying Td and to drop of Humidity Drying Rd
7.	SUR-AM-7	off	off	Off	To stay of Temperature Drying Td and to stay of Humidity Drying Rd

8.	SUR-AM-8	H	D ₁	Off	To stay of Temperature Drying T _d and to adjust Humidity Drying R _d with Humidity ambient H _a [Equalizing-Process]
----	----------	---	----------------	-----	---

Note:D₁: Damper ON: 5'D₂ : Damper ON: 2'D₃ : Damper ON: 1'

S : Sprayer ON: 1'

H : Heater ON : 15'

H₁ : Heater ON: 10'H₂ : Heater ON: 5'**4 Discussion**

Diagram the *optimal fuzzy controller* with linier gain is represented at figure 7. The implemented of control system doing is necessary of schedule of drying, conditions of air parameter, and weather represented at table 7 [9].

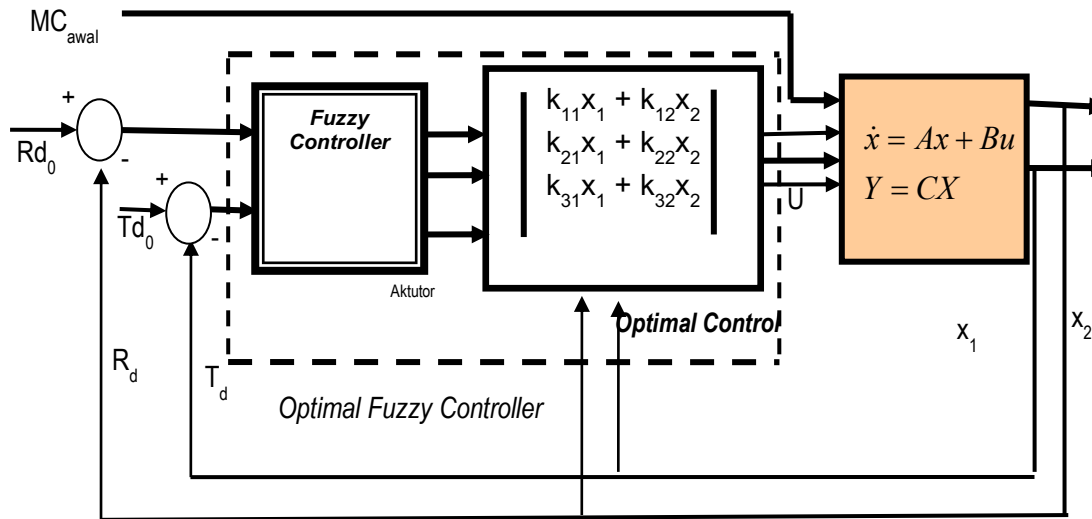

Fig. 7: *Optimal Fuzzy controller* with Gain K

Optimisation for solar energy used, based of look up table actuator doing “ON” or “OFF”, and anticipation for changes of weather and conditions of air anticipation, represented by table 7.

Adaptif Fuzzy Controller

The problem is how the Adaptive fuzzy controller implemented to control system drying process at change of humidity but temperature constant. The adaptation mechanism adjusts to the membership function according to measurement data [10]. The most important part of a dehumidifying kiln is a heat pump. Air in the kiln passes through the load of timber and absorbs moisture from the wood. Part of that air circulates through the heat pump where the moisture is condensed and drained out of the chamber. Dried, reheated air comes back to kiln chamber. Energy consumption is minimal, since there is almost no inner/outer air exchange. Air circulation in these kilns is smaller than in conventional kilns, while the electrical power of flow fans and heat pump equals approximately the power of flow fans in conventional kilns.

Logic of fuzzy used to mechanism adapt the adaptive fuzzy controller, and reference of control is schedule of drying for albasia albasia wood and model mathematic model change of humidity in shown equations (7). Simply of equation (1) to have at equations (8). Schedule to adapt of drying albasia albasia wood in shown at step 3 and step 4. in table 6

$$\frac{dR_d}{dt} = a_{21}T_d + a_{22}R_d + b_{22}u_2 + b_{23}u_3 \quad (7)$$

$$a_{21} = -\frac{a_g AP_{sd0}}{V\rho} ; a_{22} = -\frac{b_g AP_{sd0}(1-R_{d0})}{V\rho} \approx 0;$$

$$b_{22} = \frac{1}{V\rho} \approx 0 ; b_{23} = -\frac{1}{V\rho C_d} \approx 0$$

$$u_2 = m_s \text{ and } u_3 = Q_d \quad \frac{dR_d}{dt} \approx a_{21}T_d \tag{8}$$

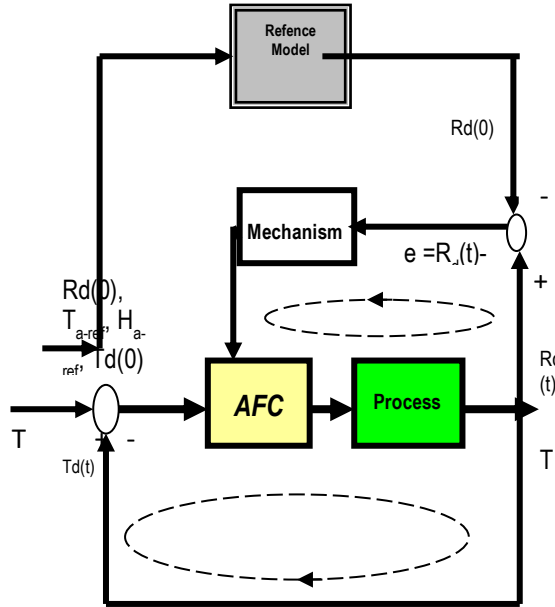

Fig. 8: Control mechanism of Adaptive Fuzzy Controller

IF u_{1i} is F_{1i} AND u_{2i} is F_{2i} AND.....

..... AND u_{ni} is F_{Ni} THEN y is Y_i

(9)

With, u : input controller

y : output controller

F_{Ni} : Membership Functions in Gaussian typical

Y_i : singleton output

Input variable in measurement by SHT11-sensor and shown in table 8. And output variable at table 9.

Table 8: Input variable of Adaptive Fuzzy Controller

No.	Nama Variable	Range
1.	Drying Temperature Td	0 – 150 °C
2.	Ambient Ambient Ta	0 – 150 °C
3.	Drying Humidity Rd	0 – 100 %
4.	Ambient Humidity Ha	0 – 100 %

Table 9: Output variable of Adaptive Fuzzy Controller

No	RULE	Describe			Goal
		Heater	Damper	sprayer	
1.	AFC-1	off	off	off	To stay of humidity at condition initial
2.	AFC-2	H	off	off	To drop of humidity with very fast

3.	AFC-3	H ₁	off	off	To drop of humidity with fast
4.	AFC-4	H ₂	off	off	To drop of humidity
5.	AFC-5	off	D ₁	off	To hoist of humidity as use as humidity ambient with very fast
6.	AFC-6	off	D ₂	off	To hoist of humidity as use as humidity ambient with fast
7.	AFC-7	off	D ₃	off	To hoist of humidity as use as humidity ambient
8.	AFC-8	H ₁	D ₁	off	To drop of humidity with energy from heater as fast
9.	AFC-9	H ₂	D ₂	off	To drop of humidity with energy from heater as slowly
10.	AFC-10	H ₂	D ₃	off	To drop of humidity with energy from heater as very slowly
11.	AFC-11	H ₂	D ₁	off	To stay of humidity with energy from heater
12.	AFC-12	H ₁	off	on	To hoist the humidity with humidifying by sprayer
13.	AFC-13	H ₂	off	on	To hoist the humidity with humidifying by sprayer as fast
14.	AFC-14	H ₂	D ₁	on	To hoist the humidity with humidifying by sprayer as use as humidity ambient

With:

D₁ : Priod ON *damper* : 5'

D₂ : Priod ON *damper* : 2'

D₃ : Priod ON *damper* : 1'

H : Priod ON heater : 15'

H₁ : Priod ON heater : 10'

H₂ : Priod ON heater : 5'

On : Priod ON *Sprayer* : 1'

The fuzzy adaptive controller design incorporates adaptive control-based schedule of drying under conditions the temperature of chamber is constant but change for humidity of chamber. Analysis of parameter control and system used mechanism to adapt for set-point in model, condition of chamber represented process control of actuator. Rule AFC was the impact of implementation of fuzzy adaptive controller using fuzzy logic based on analysis [11]. Rule control of analysis logic fuzzy in process wood drying described in equation 9.

IFC Implementation

Block diagram of IFC shown in figure 5, and Hardware IFC system at shown in figure 9.

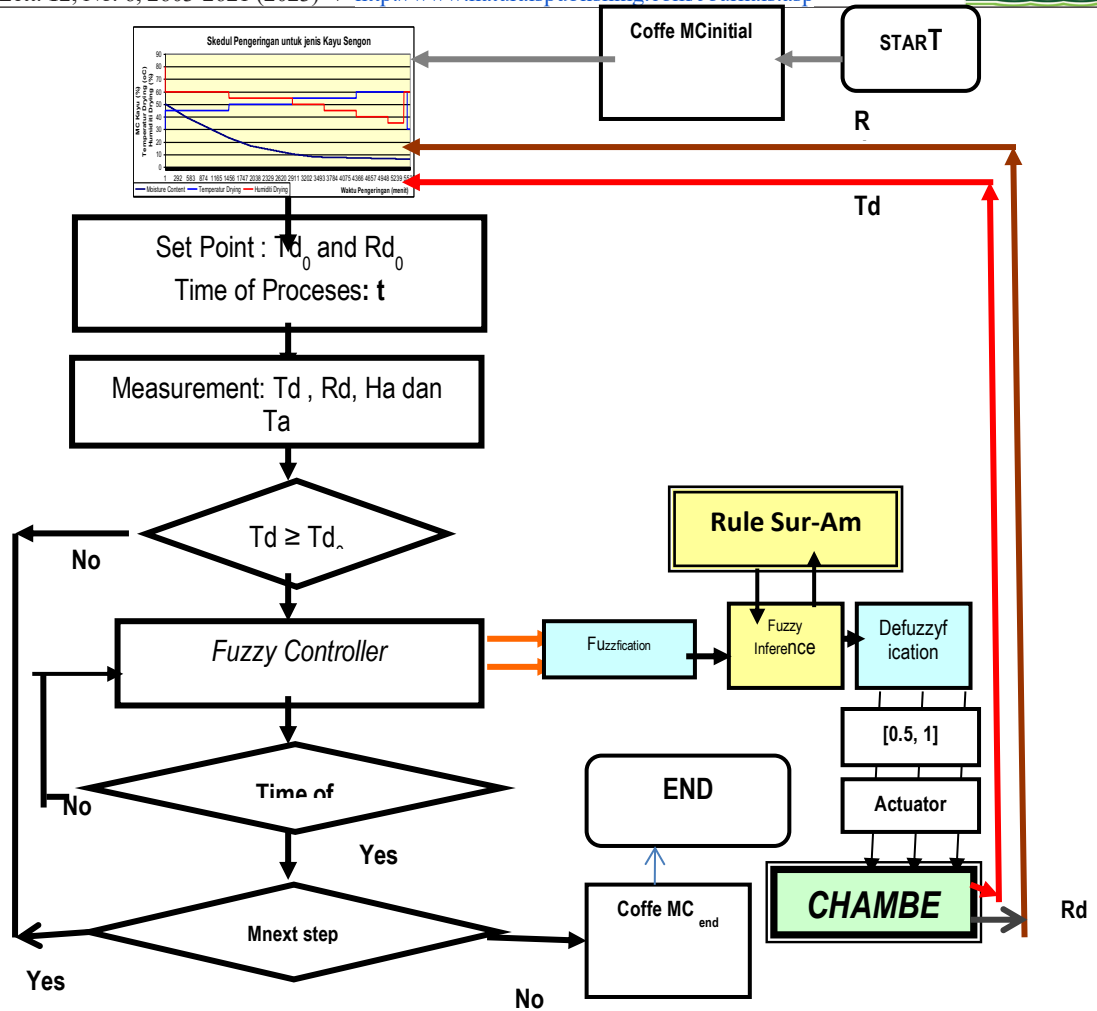

Fig. 9: Block Diagram of Intelligent Fuzzy Controller

Intelligent fuzzy controller is a hybrid controller included optimal fuzzy controller, fuzzy controller, and adaptive fuzzy controller. Design of membership function the algorithm process. The algorithm was the development of rule of fuzzifications and input-output pairs, and it implemented for a solar energy wood drying process kiln. The membership function must be stability high and flexible for weather and performance derived from gain process, time constant and time delay of system. The developed control system involves the control of temperature at different zones, of ambient humidity, and of the ambient humidity. The system model is developed using a system identification scheme based on the online input/output data and knowledge accumulated through extensive tests. The knowledge base of the fuzzy tuner is derived from the drying schedule for a specific wood specimen.

Measurement of temperature drying and humidity drying with the IFC will reach the parameter control and tuning system. Initial moisture content $MC > 50\%$ of material, used for experiment of implemented IFC, and result of process shown in figure 10.

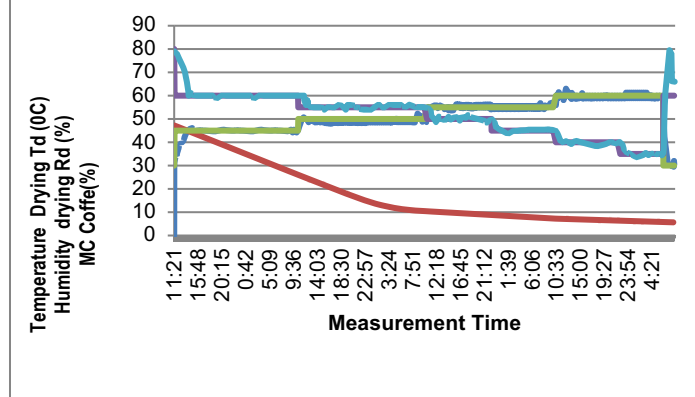

Fig. 10: Implemented of IFC for drying system the coffee drying process on 12 - 19 April 2021

The result of experiment shows the system IFC can be doing as well and rate of elevation from set point 1.2°C for measurement of temperature and 2.5% for measurement of humidity. Tuning of IFC system by addition alarm setting system for hardware system measurement of temperature drying. Efficiency system IFC can reach 66% and maximize to used solar energy for drying process.

The next experiment doing of the material with MC at $57,17\%$. The result of measurement of temperature and humidity drying. And ON-OFF controller shown at figure.11.

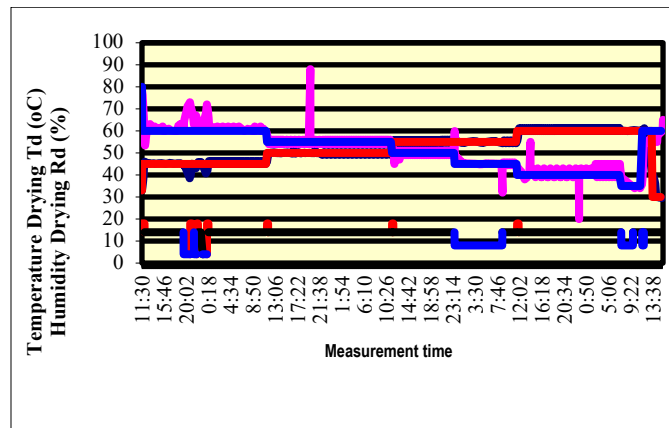

Fig. 11: Implemented of IFC for drying system

The result measurement shows the temperature and humidity drying capable follow track the set point with smooth schedule of drying.

Total time of drying with fuzzy controller is 5010 minutes. Optimal fuzzy controller used: 125 minutes, and adaptive fuzzy controller used 714 minutes. Time constant system is 28 minutes for temperature drying and 56 minutes for humidity drying and shown at figure 12.

An intelligent fuzzy controller algorithm is used to adjust the use of the controller according to the drying schedule. The results show that the proposed approach for overall control has a great potential for performance improvement when applied to other industrial kilns. Intelligent fuzzy controller is implemented as well and its performance is compared with that of the conventional controller, smoother, robustness and controllability.

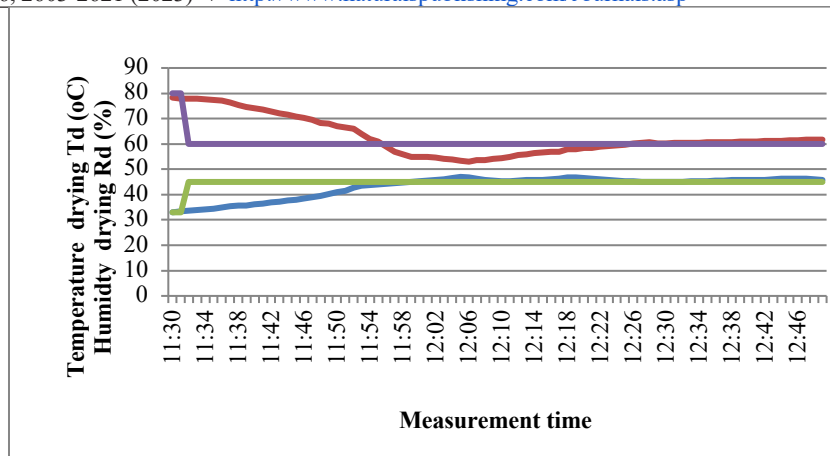

Fig. 12: Time constant for implemented of IFC

Fuzzy Rule Suram

This Fuzzy Rule Suram is a fuzzy logic-based rule containing weather conditions and air conditions which are implemented in the coffee drying process. Obtained 16 output control rules by utilizing fuzzy logic operators implemented in a solar coffee dryer, the performance of this fuzzy controller will optimize the use of solar energy, to minimize the consumption of electrical energy by the heater, according to wind speed. This control rule is needed to maintain a chamber condition according to the coffee drying schedule. To maximize the use of solar energy, it is necessary to have a control system that is responsive to changes in the amount of solar energy and environmental temperature. SURAM's Fuzzy Rule is able to optimize the use of solar energy and is responsive to changes. This process will provide hope for minimal use of electrical energy and the system will quickly respond to changes in environmental conditions.

The advantage of the SUR-AM Rule is that it reduces the time delay of the actuator response, where to activate the actuator, it is not necessary to process the influence of solar energy on the temperature and humidity of the drying chamber and/or the effect on changes in moisture content. This is the intelligence of the fuzzy controller system so that the coffee drying process can be maintained at the expected conditions. For computation of the fuzzy rule suram, it begins by entering the initial value of the water content in MC coffee = 54%. According to the drying schedule, the drying chamber temperature is set at $Td_0 = 60\text{ }^\circ\text{C}$ and the humidity in the drying room is $Rd_0 = 65\%$ and wind speed = 1.2 m/s. Furthermore, the measurement data showed that the ambient temperature $Ta = 29.2\text{ }^\circ\text{C}$, Humidity ambient $Ha = 64\%$. In the next measurement, it was obtained that $Ta (n + 1) = 29,6\text{ }^\circ\text{C}$ and $Ha (n + 1) = 64.2\%$, where measurements are carried out every 5 minutes.

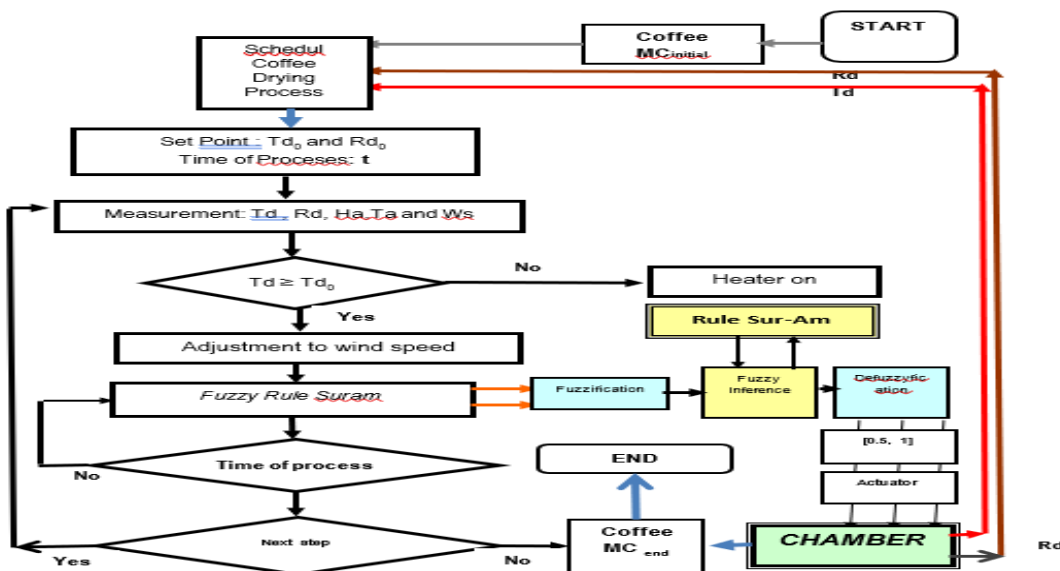

Fig. 12: Block Diagram of Fuzzy Rule

From equation (5), it is found that the change in the ambient temperature value is $CTa(n+1) = Ta(n+1) - Ta = 29.6 - 29.2 = 0.4$ oC. From Figure 3, it is found that there are two membership values of $Ta = 29.2$, namely cloudy: B and CB: clear clouds, respectively: $\mu_B = 0.9$ and $\mu_{CB} = 0.1$, according to Figure 3. Similarly, the change is $CTa = 0.8$ oC according to Figure 4, $Ha = 64\%$ is at $S = \text{Fresh}$ with a membership value of $\mu_s = 1.0$ and the change in humidity $CHa = 0.2\%$ is at $\mu_z = 0.8$ and $\mu_s = 0.2$.

From table 3 it is obtained with conditions $B = 0.9$ and $CB = 0.1$ at the position of change + M, then the weather conditions are claud with membership value = 0.9 and Bright Claud = 0.1. Likewise for the air condition in table 4. stated in the Fresh state with a maximum membership value of 0.8. And the possibilities that occur from each combination of weather conditions and air conditions are stated in table 10, table 11, and table 12.

Table 10: Implementation of Fuzzy Rule SURAM on Condition: $Td [(n+1)] < Td_0$

N0.	IF	AND	AND weather conditions is	AND air conditions is	THEN OUTPUT is (Table 5 and 6)
1	$T_d [(n+1)] < T_{d_0}$	$R_d [(n+1)] > R_{d_0}$	Over-Cloud	Hot	SUR-AM - 2
2				Rather Hot	SUR-AM - 2
3				Swam	SUR-AM - 2
4				Fresh	SUR-AM - 2
5				Cold	SUR-AM - 2
6			Cloud	Hot	SUR-AM - 2
7				Rather Hot	SUR-AM - 2
8				Swam	SUR-AM - 2
9				Fresh	SUR-AM - 2
10			Cold	SUR-AM - 2	
11			Bright-Cloud	Hot	SUR-AM - 2
12				Rather Hot	SUR-AM - 2
13				Swam	SUR-AM - 2
14				Fresh	SUR-AM - 2
15			Cold	SUR-AM - 2	
16			Clear	Hot	SUR-AM - 3
17				Rather Hot	SUR-AM - 2
18				Swam	SUR-AM - 2
19				Fresh	SUR-AM - 2
20			Cold	SUR-AM - 2	
21			clearest	Hot	SUR-AM - 3
22				Rather Hot	SUR-AM - 3
23				Swam	SUR-AM - 2
24				Fresh	SUR-AM - 2
25			Cold	SUR-AM - 2	
26			$R_d [(n+1)] \leq R_{d_0}$	Over-Cloud	Hot
27		Rather Hot			SUR-AM - 3
28		Swam			SUR-AM - 3
29		Fresh			SUR-AM - 3
30		Cold		SUR-AM - 3	
31		Cloud		Hot	SUR-AM - 3
32				Rather Hot	SUR-AM - 3
33				Swam	SUR-AM - 3
34				Fresh	SUR-AM - 3
35		Cold		SUR-AM - 3	
36		Bright-Cloud		Hot	SUR-AM - 4
37				Rather Hot	SUR-AM - 4
38				Swam	SUR-AM - 3
39				Fresh	SUR-AM - 3
40		Cold		SUR-AM - 3	
41		Clear		Hot	SUR-AM - 4
42			Rather Hot	SUR-AM - 4	

43				Swam	SUR-AM - 4
44				Fresh	SUR-AM - 3
45				Cold	SUR-AM - 3
46			Clearest	Hot	SUR-AM - 4
47				Rather Hot	SUR-AM - 4
48				Swam	SUR-AM - 4
49				Fresh	SUR-AM - 3
50				Cold	SUR-AM - 3

Table 11: Implementation of Fuzzy Rule SURAM on Condition $T_d [(n+1)] = T_{d0}$

N0.	IF	AND	AND weather conditions is	AND air conditions is	THEN OUTPUT is
1.	$T_d [(n+1)] = T_{d0}$	$R_d [(n+1)] > R_{d0}$	Over-Cloud	Hot	SUR-AM - 2
2.				Rather Hot	SUR-AM - 2
3.				Swam	SUR-AM - 2
4.				Fresh	SUR-AM - 2
5.				Cold	SUR-AM - 2
6.			Cloud	Hot	SUR-AM - 2
7.				Rather Hot	SUR-AM - 2
8.				Swam	SUR-AM - 2
9.				Fresh	SUR-AM - 2
10.			Cold	SUR-AM - 2	
11.			Bright-Cloud	Hot	SUR-AM - 3
12.				Rather Hot	SUR-AM - 3
13.				Swam	SUR-AM - 2
14.				Fresh	SUR-AM - 2
15.			Cold	SUR-AM - 2	
16.			Clear	Hot	SUR-AM - 3
17.				Rather Hot	SUR-AM - 3
18.				Swam	SUR-AM - 3
19.				Fresh	SUR-AM - 2
20.			Cold	SUR-AM - 2	
21.			clearest	Hot	SUR-AM - 3
22.				Rather Hot	SUR-AM - 3
23.				Swam	SUR-AM - 3
24.				Fresh	SUR-AM - 2
25.			Cold	SUR-AM - 2	
26.		$R_d [(n+1)] \leq R_{d0}$	Over-Cloud	Hot	SUR-AM - 3
27.				Rather Hot	SUR-AM - 3
28.				Swam	SUR-AM - 3
29.				Fresh	SUR-AM - 3
30.			Cold	SUR-AM - 3	
31.			Cloud	Hot	SUR-AM - 3
32.				Rather Hot	SUR-AM - 3
33.				Swam	SUR-AM - 3
34.				Fresh	SUR-AM - 3
35.			Cold	SUR-AM - 3	
36.			Bright-Cloud	Hot	SUR-AM - 6
37.				Rather Hot	SUR-AM - 6
38.				Swam	SUR-AM - 3
39.				Fresh	SUR-AM - 3
40.			Cold	SUR-AM - 3	
41.			Clear	Hot	SUR-AM - 6
42.				Rather Hot	SUR-AM - 6
43.				Swam	SUR-AM - 3

44		clearest	Fresh	SUR-AM-3
45			Cold	SUR-AM-3
46			Hot	SUR-AM-6
47			Rather Hot	SUR-AM-6
48			Swam	SUR-AM-6
49			Fresh	SUR-AM-3
50			Cold	SUR-AM-3

Table 12: Implementation of Fuzzy Rule SURAM on Condition : $T_d [(n+1)] > T_{d0}$

NO.	IF	AND	AND weather conditions is	AND air conditions is	THEN OUTPUT is					
1	$T_d [(n+1)] > T_{d0}$	$R_d [(n+1)] > R_{d0}$	Over-Cloud	Hot	SUR-AM-2					
2				Rather Hot	SUR-AM-2					
3				Swam	SUR-AM-2					
4				Fresh	SUR-AM-2					
5				Cold	SUR-AM-2					
6			Cloud	$R_d [(n+1)] > R_{d0}$	Over-Cloud	Hot	SUR-AM-2			
7						Rather Hot	SUR-AM-2			
8						Swam	SUR-AM-2			
9						Fresh	SUR-AM-2			
10			Cold			SUR-AM-2				
11			Bright-Cloud		$R_d [(n+1)] > R_{d0}$	Over-Cloud	Hot	SUR-AM-5		
12							Rather Hot	SUR-AM-5		
13							Swam	SUR-AM-2		
14							Fresh	SUR-AM-2		
15			Cold				SUR-AM-2			
16			Clear			$R_d [(n+1)] > R_{d0}$	Over-Cloud	Hot	SUR-AM-5	
17								Rather Hot	SUR-AM-5	
18								Swam	SUR-AM-5	
19								Fresh	SUR-AM-2	
20			Cold					SUR-AM-2		
21		Bright-Cloud	$R_d [(n+1)] > R_{d0}$				Over-Cloud	Hot	SUR-AM-5	
22								Rather Hot	SUR-AM-5	
23								Swam	SUR-AM-5	
24								Fresh	SUR-AM-2	
25		Cold						SUR-AM-2		
26		$R_d [(n+1)] \leq R_{d0}$		$R_d [(n+1)] \leq R_{d0}$			Over-Cloud	Hot	SUR-AM-3	
27								Rather Hot	SUR-AM-3	
28								Swam	SUR-AM-3	
29								Fresh	SUR-AM-3	
30							Cold	SUR-AM-3		
31					Cloud		$R_d [(n+1)] \leq R_{d0}$	Over-Cloud	Hot	SUR-AM-3
32									Rather Hot	SUR-AM-3
33									Swam	SUR-AM-3
34									Fresh	SUR-AM-3
35					Cold			SUR-AM-3		
36					Bright-Cloud	$R_d [(n+1)] \leq R_{d0}$		Over-Cloud	Hot	SUR-AM-6
37									Rather Hot	SUR-AM-6
38									Swam	SUR-AM-6
39									Fresh	SUR-AM-7
40					Cold			SUR-AM-7		
41			Clear		$R_d [(n+1)] \leq R_{d0}$			Over-Cloud	Hot	SUR-AM-6
42									Rather Hot	SUR-AM-6
43									Swam	SUR-AM-6
44		Fresh		SUR-AM-7						

45				Cold	SUR-AM-7
46				Hot	SUR-AM-6
47				Rather Hot	SUR-AM-6
48			clearest	Swam	SUR-AM-6
49				Fresh	SUR-AM-7
50				Cold	SUR-AM-7

From the computational results it is obtained that the output used of the treatment of the actuator is Rule Suram 2, according to table 10. Furthermore, from table 10 the Rule Suram 2 is Heater ON, Damper OFF, and Sprayer OFF, the meaning is Increase Drying Temperature suddenly and decrease Drying Chamber Humidity Rd. And From equation 1, the required solar energy is: $I_o = 617 + 9.7(T_{do} - 45)$ (watt/m²) = 617 + 9.7 (60 - 45) = 617 + 145.5 = 762.5 Watt/ m².

The measurement was carried out in Kampung Salaon-dolok, Samsir Island, North Sumatra, Indonesia, as a coffee-producing area on Monday, April 12, 2021, at: 10.30 WIB. The prototype was prepared for the drying process of 100 kg of coffee with an average moisture content of 54.75%. Initial conditions: Initial temperature: 29.2 °C and humidity of 64%. The drying process is carried out for 7 full days, so that the drying process is completed on Monday, April 19, 2021, at 7.30 WIB.

Parameter measurement results are presented in Figure 13. namely Coffee Moisture Content, Drying Chamber Temperature, Humidity Chamber, every 5 minutes.

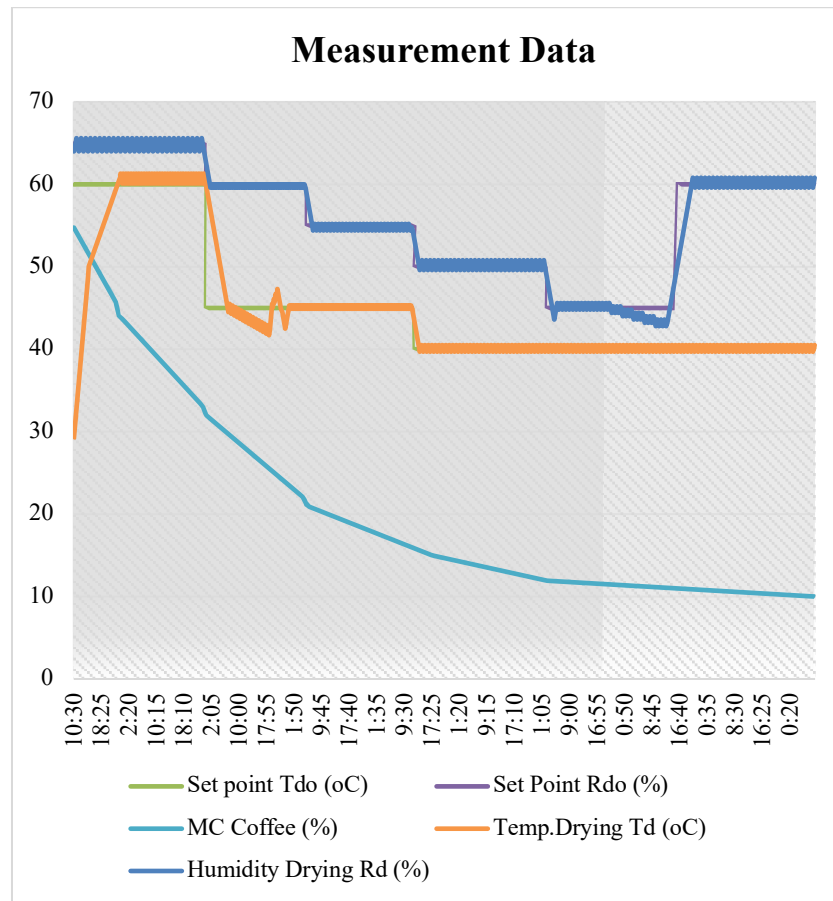

Fig. 13: Measurement results: Moisture Content of MC coffee, Temperature Drying, and Humidity Drying on April 12 - 19 2021

From the measurement results, it is shown that the Fuzzy Rule Suram algorithm is able to follow the coffee drying schedule. It is also shown that coffee drying reaches the average Moisture content of coffee MC = 10%.

The results of measurements of solar energy in the coffee drying process on April 12 - 19 2021 are presented in Figure 14, showing that the solar energy used is 40, 86% of the total energy requirement. Solar energy is utilized maximally during the day and at night using a heater using electrical energy. For further development, a solar energy storage system is needed, so that it can be utilized at night.

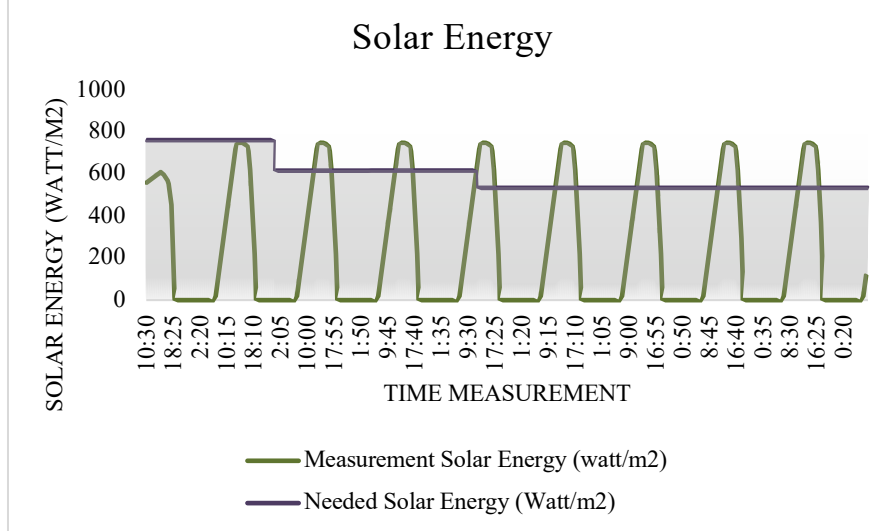

Fig. 14: Measurement results of solar energy in the coffee drying process on 12 - 19 April 2021

5 Conclusion

Intelligent fuzzy controller is used a hybrid controller included optimal fuzzy controller, fuzzy controller, and adaptive fuzzy controller. Design of membership function used to arrange algorithm process. The algorithm was developed based on conditions and input-output pairs, and it was implemented for a solar energy of the coffee drying process kiln. The membership function must be stable high and in accordance with weather and performance derived from gain process, time constant and time delay of the system with 8 rules. The proposed approach for overall control has a great potential for performance improvement when applied to other industrial kilns. Intelligent fuzzy controller is implemented as well and its performance is compared with that of the conventional controller, smoother, robustness and controllability with 22 rules.

The Fuzzy Rule Suram Algorithm in the coffee drying process is based on fuzzy logic with modified membership functions in the range $[0,5, 1]$ on the parameters of weather conditions and air conditions in the form of ambient temperature and ambient humidity. In the computational process of this algorithm, 16 fuzzy rules to control the output system can be built which consist of 8 rules, each for conditions of high wind speed above 2.8 m/s, and low wind speed. There are 3 x 50 treatments for the heater actuator, damper and sprayer, based on the real humidity conditions of the drying room and the humidity according to the drying schedule. From the results of the implementation on the prototype of this coffee dryer, the utilization of solar energy is 40.86% of the required energy. It is due to the acceleration of the drying process day and night continuously, but it can reduce processing time from 21 days to 7 days.

Conflict of interest

The authors declare that there is no conflict regarding the publication of this paper.

References

- [1] Z. Situmorang, Fuzzy Rule Suram For Wood Drying, *Journal of Physics: Conference Series*, vol. 930, no. 1. 1-8 (2017)
- [2] Z.Situmorang and J. A. Situmorang, Intelligent fuzzy controller for a solar energy wood dry kiln process, *TIME-E*.2015.7389765, 152-157, (2016)
- [3] Z. Situmorang and A. E. Husein, Fuzzy Rule Suram for Controlling Drying Process System, *Techniques and Innovation in Engineering Research Vol. 5*, B P Internatioanal,1-34,(2023).
- [4] Z. Situmorang and R. Wardoyo, Extended Fuzzy Rule Suram for Coffee Drying System, *Am. J. Multidiscip. Res. Innov.*, vol. 2, no. 1, 9-21, (2023).
- [5] S. P. Ishwarya and C. Anandharamakrishnan, Spray-Freeze-Drying approach for soluble coffee processing and its effect on quality characteristics, *J. Food Eng.*, vol. 149, 171-180, (2015)

- [6] B. Bond, Design and Operation of a Solar-Heated Dry Kiln, *Virginia Polytechnic Institute and State University*, 1-10, 2009.
- [7] S. Suherman, H. Widuri, S. Patricia, E. E. Susanto, and R. J. Sutrisna, Energy analysis of a hybrid solar dryer for drying coffee beans, *Int. J. Renew. Energy Dev.*, vol. 9, no. 1, 131-139,(2020)
- [8] P.P.K. Lim, N. R. Spooner, and B. Gatland, Climatic control of a storage chamber using fuzzy logic, Proceedings Second New Zealand International Two-Stream Conference on Artificial Neural Networks and Expert Systems, 141-144, (1995)
- [9] Z. Situmorang, R. Wardoyo, S. Hartati, and J. E. Istiyanto, Computation of parametric adaptive fuzzy controller for wood drying system, *AIP Conference Proceedings*, vol. 1159, 170-177, (2009)
- [10] Z. Situmorang, R. Wardoyo, S. Hartati, and J. E. Istiyanto, Fuzzy rule Suram for control system of a solar energy wood drying chamber, *AIP Conference Proceedings*, vol. 1159, 103-110, (2009)
- [11] P. Perré and M. Campean, 8th International IUFRO Wood Drying Conference: Brasov-Romania, *Maderas. Cienc. y Technol.*, vol. 5, no. 1, 90-91, (2003).
- [12] C. T. Chao, N. Sutarna, J. S. Chiou, and C. J. Wang, An optimal fuzzy PID controller design based on conventional PID control and nonlinear factors, *Appl. Sci.*, vol. 9, no. 6,1-18, 2019
- [13] X.G. Wang, W. Liu, L. Gu, Colin Jian Sun, Caikang Elton Gu, and C. W. De Silva, Development of an intelligent control system for wood drying processes, *IEEE/ASME International Conference on Advanced Intelligent Mechatronics AIM, Vol.1*, 371-376, (2001).
- [14] M. N. Haque, Modelling of Solar Kilns and the Development of Anoptimised Schedule for Drying Hardwood Timber, *Ph.D. thesis*, The University of Sydney, (2002).
- [15] Z. Zhou and K. Wang, Sliding mode controller design for wood drying process, *Wood Sci. Technol.*, vol. 52, no. 4, 1039-1048, (2018)
- [16] J. Muhidong, Mursalim, and A. Rahman, The effect of air flow rate on single-layer drying characteristics of Arabica coffee, *Int. Food Res. J.*, vol. 20, no. 4, 1633-1637, (2013).
- [17] I. W. Coffee, Design Of A Small-Scale Hulling Machine For Improved Wet-Processed Coffee, *Int. J. Sci. Technol. Res.*, vol. 6, no. 8, 391-397, (2017).
- [18] K. Kusmiyati and A. Fudholi, Solar-Assisted Microwave Convective Dryer for Coffee Cherries, *Int. J. Renew. Energy Res.*, vol. 11, no. 1, 407-415, (2021).
- [19] P. Ghosh and N. Venkatachalapathy, Processing and Drying of Coffee - A review, *Int. J. Eng. Res. Technol.*, vol. 3, no. 12, 784-794, (2014).
- [20] E. Firdissa, A. Mohammed, G. Berecha, and W. Garede, Coffee Drying and Processing Method Influence Quality of Arabica Coffee Varieties (Coffee arabica L.) at Gomma I and Limmu Kossa, Southwest Ethiopia,” *J. Food Qual.*, vol. 2022, 1-8, (2022).