

Survey of Wearable Sensors with Comparative Study of Noise Reduction ECG Filters

A. Rehman¹, M. Mustafa², I. Israr³, M. Yaqoob⁴

¹*Department of Electrical Engineering, COMSATS Institute of Information Technology, Islamabad, Pakistan*
Email Address: aziz.cust@yahoo.com

²*Department of Electrical Engineering, COMSATS Institute of Information Technology, Islamabad, Pakistan*
Email Address: mansoor.mustafa22@gmail.com

³*Department of Electrical Engineering, COMSATS Institute of Information Technology, Islamabad, Pakistan*
Email Address: imranisrarch@hotmail.com

⁴*Department of Electrical Engineering, COMSATS Institute of Information Technology, Islamabad, Pakistan*
Email Address: mateenyaqoob@gmail.com

Received: 2 Oct. 2012, Revised: 10 Oct. 2012; Accepted 23 Nov. 2012

Abstract: Wearable sensors are the major part of Wireless Body Area Networks (WBANs) for provision of health care services and physical activity monitoring. In this paper, a brief survey of different types of wearable sensors presented along with sensor placement. Designing of wearable sensors for ECG and Blood pressure also discussed. Comparative study of FIR and IIR noise reduction ECG filters discussed at the end. With the help of MATLAB R2008b, different types of FIR and IIR filters designed to remove Baseline Wander Noise, Muscle Noise and Power line Interference from raw ECG signals of different subjects and have compared which filter provides best result.

Keywords: Wearable Sensors, Accelerometers, ECG, FIR, IIR

I. Introduction

Rapid increase in world population of elderly people have drawn attention from researchers to develop a system that reduces health-care cost, efficient utilization of physician skills, remote access to patients for continuous monitoring and analysis feedback to patients to reduce severe health related issues. The advancements in wireless communication and semiconductor technologies have huge impact on the sensor networks for medical application. A WBAN (Wireless Body Area Network) is a collection of wireless sensor nodes placed around or in a human body that are used to exchange important information from human body to remote stations.

Wireless wearable sensors are major part of this healthcare system, that works as sensing node and measure different physiological signals such as heart rate, body and skin temperature, blood pressure, Electrocardiography (ECG), Electroencephalogram (EEG), Electromyography (EMG) signals, oxygen saturation and respiration rate etc. These collected signals transferred to a central node or Coordinator or Data aggregator or Gateway. Coordinator node provides the connectivity with the external database server or medical server as shown in Fig. 1. Coordinator can use different communication networks for the transmission of data to the medical server. Usually WBANs use mobile phone data networks such as 3G and 4G to transmit required information to the server, however other data networks such as standard telephone network, a dedicated medical centre or hospital data network, mobile phone network and WLAN (Wireless Local Area Network) hotspots can also be used for data transmission. The healthcare providers are increasingly looking for advanced communication and technological systems that can efficiently manage the delivery of information for a range of services. These systems should have the ability to deliver healthcare

services not only to patients in hospitals; but also in their homes and workplaces in an efficient and cost effective way to improve quality of life of the patients. Mobility is a key part in healthcare system, for this purpose wearable sensors must be small in size, power efficient, low weight and should have wireless module for wireless communication. In conventional healthcare systems specialized monitoring equipment used to monitor the patients and these systems can also send data using some kind of data networks to the medical servers. However, these systems does not have support for mobility due to use of wired wearable sensors. WBANs introduce the concept of location independent monitoring systems due to this its applications not only limited to healthcare systems but also extended in different sports categories and physical activity monitoring etc.

In our previous work [1], we have briefly discussed the types of wearable sensor with their designing issues, however in this paper wireless wearable sensors for health and physical activity monitoring are reviewed with the sensor placement issues and noise reduction ECG filters. Section II presents different types of wearable sensor that are used for detection and prediction of different motion scenarios and physical activities. Whereas, in section III different sensor placement locations are discussed. In section IV, we present a survey about designing of different types of wearable sensors specifically for ECG and blood pressure. Section V includes brief description about some of ECG noise removal filters and section VI presents designing of filters and simulation results of noise free ECG signals. Section VII presents conclusion and future work.

II. TYPES OF WEARABLE SENSORS

With increase in population and changing life styles there is urgency to develop a system that can monitor patient activities and daily routines to prevent them from serious health related disorders [2]. Advancements in wearable sensors and wireless technologies create huge impact on health-care monitoring system. Now we have facilities to monitor patients from remote location on continuous basis by using wearable sensors and wireless systems. Different types of sensors available for specific applications.

A. Accelerometer

Accelerometer sensors or motion detection sensors are used to sense acceleration (change in body position), this acceleration might be linear or angular. Operational principle of accelerometer is based on an element named proof mass that attached to a suspension system with respect to reference point and when force applied on proof mass, deflection is produced in it. Produced deflection can be measured electrically to sense changes in body location [3], [4]. Accelerometers are most commonly used sensors to monitor physical activities of persons who recently recovered from brain disease [5]. It specifically used in rehabilitation process of stroke and Parkinson survivors to check the level of mobility, also used in analysis of gait.

B. Electromagnetic Tracking System (ETS) Sensor

ETS is a body position measurement sensor based on Faraday's law of magnetic induction [6]. When a person or object that carry a sensor consists of coils perform a motion inside a controlled magnetic field, the induced voltage in sensor coils will change with respect to the change of the objects position and orientation relative to source of controlled magnetic field. This controlled magnetic field is generated by a fixed transmitter and detected by a receiver fixed on an object. By using this phenomena position and orientation of moving object can be calculated [7]. ETS is an important sensor in gait analysis and in study of body kinematics

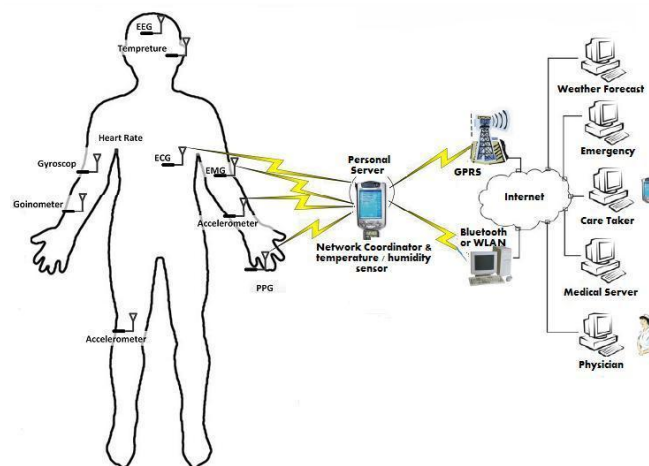

Figure 1. Wireless Body Area Network Scheme

C. Ground Reflection Force (GRF) Sensor

GRF sensor is used to realize ambulatory measurements of ground reflection force during gait analysis. It is a three dimensional vector, with actual direction depending upon the nature of interface between ground and foot. Shoe based GRF sensor is an alternative of old conventional techniques that were used in laboratory for gait analysis such as instrumented treadmill devices [7]. In [8], [9], authors developed a shoe based GRF sensor by fixing two externally mounted sensors beneath front and rear part of a special shoe. In [7], authors proposed a new shoe based GRF sensor by using five small triaxial sensors beneath shoe. They aligned each coordinate of sensor with global coordinate systems; then collect data about each sensor position in accordance to reference positions and use this data to analyze different parameters. This GRF sensor used to measure Center of Pressure (CoP) in ambulatory measurements and also used to analyze kinetics of ankle, knee and hip joints.

D. EMG Sensor

In EMG electrical activities of particular muscle is monitored. During muscle contraction microvolt level electrical signals produced, that can be measured from skin surface. In other words EMG measures the action of muscles. Basically two types of EMG sensors are used, needle EMG and surface EMG. Surface EMG or sEMG is used when only basic or general information of muscle activity is required, whereas, in needle EMG, needle must be inserted inside designated muscle which required to be studied. Needle EMG sensors are used to acquire some detailed information about specific muscle [10]. EMG specifically used to study the performance of persons who suffered from skeletal problems for example used in localized muscle fatigue and gait analysis to study muscle force.

E. ECG Sensor

ECG is interpretation of electrical activity of heart over a period of time across chest area whose purpose is to record activities of heart during its contraction and relaxation. In conventional methods a number of electrodes were attached on body surface around chest area that measures electrical signals during heart contraction process. Received signals from electrodes were recorded to an external device called holter. It is impossible from traditional system to perform ECG at remote location. With the advancements in technology different ideas were presented to replace wired holter with wireless holter system. Design of

electrodes is also important factor in continuous monitoring that these electrodes should not damage the skin. Different electrodes were used to monitor heart activities from remote locations for continuous period, for example use of dry electrodes, electrodes made up of plastic material or rubber. However all these type of electrodes cause skin irritation problems.

In [11], authors proposed an idea to use non-contact capacitive sensing mechanism, in which capacitive electrodes can sense heart signals through clothes. They propose an idea of using two gold coated electrodes on each arm (wrist) surface and record ECG by using single channel between each arm and results show an error heart rate within range of 1%. In [12], authors develop a single chip based ECG sensor that consists of two conductive fabric electrodes to detect heart signals. This wearable ECG sensor amplifies detected signals and then transmits to server.

F. EEG Sensor

EEG is a process to measure brain waves of a person, in its conventional method a number of electrodes are placed on scalp; these electrodes detect microvolt level signals coming from brain. Currently different methods been adopted to measure EEG for example Inpatient and Ambulatory EEG methods. But these methods also have some limitations like mobility. In Inpatient EEG method a person have to present in hospital for EEG and in Ambulatory EEG (AEEG) method a person can perform EEG at anywhere but it also has a limited mobility level because EEG monitoring system have box like device that a person have to carry all the time, and this is not a desirable situation for anybody. To overcome these issues a number of researchers present ideas about Wearable EEG sensors.

In [5], authors conduct a survey about adoptability of Wearable EEG sensors in future and they got a very good response about it. After this they propose a novel design approach of wearable EEG. In first approach they propose that wearable system of electrodes should be wireless to get rid of electrode wires, in second approach they give an idea to use Dry electrodes instead of wet or gel based electrodes. These two approaches have a drawback of placement of electrodes on scalp for long duration. To overcome this, they provide a solution to place electrodes beneath scalp skin. This approach has several advantages like electrodes will remain invisible; they will not further misplace and can be used to monitor EEG for up to eighteen months. EEG sensors are specifically used in Epilepsy and sleep studies.

G. Blood Glucose Monitoring Sensor

In conventional methods of Blood Glucose (BG) monitoring, blood sample is obtained from body by placing blood sample on a strip and then insert it into a BG calculating device to calculate Blood Glucose Level (BGL). However this conventional method is based on invasive technique, not suitable for continuous monitoring. A commercial wearable BGL monitoring sensor was developed, that has minimal invasive effect. A needle consists of electronic chip is inserted into human body to take blood sample, process it and send results wirelessly to server system. But due to shorter life duration a lot of work required on this system. Some other invasive methods were also proposed that used for continuous monitoring, these methods based on the concept of extracting fluid from skin with the help of some vacuum pressure to measure BGL [2].

Some other methods of measuring BGL non-invasively were also presented, for example by checking electrical properties of blood we can estimate BGL. But in non-invasive methods of BGL monitoring a lot of work required to be done.

III. SENSOR PLACEMENT

Sensor placement refers to location where sensors are placed. It is important aspect of wearable sensors to be placed on suitable locations. Placement of wearable sensor depends on movement of particular body organs being studied [13].

It is interesting to know that best position for sensor placement is not always on part of body where abnormality is present, however it is placed at optimum location from where required information can be easily gathered for example head-worn sensors provide the optimum location to detect body movements. In some cases; like stroke rehabilitation, sensors are placed on the particular part of body that is damaged.

It is necessary to note that placement of wearable sensor does not disturb the routine activities; like movement, walking, sleeping etc. of person wearing sensors, while designing the wearable sensor.

TABLE I. COMMON ACTIVITIES AND THEIR GROUPS

Activity	Activity Group
Lying down	Very low level activity
Preparing food, Eating, Reading	Low level activity
Walking , Vacuuming, Wiping tables	Medium level activity
Running, Cycling	High Level activity
Sitting down, Getting up, Lying Down	Transitional Activity

In practical, placement of sensor is more complicated due to subject compliance issues for example sensors attached by a belt at waist are not convenient for some women subjects who doesn't use to wear belts at waist. Elder subjects as well as those recovering from surgery cannot be asked to wear sensors for long time [14].

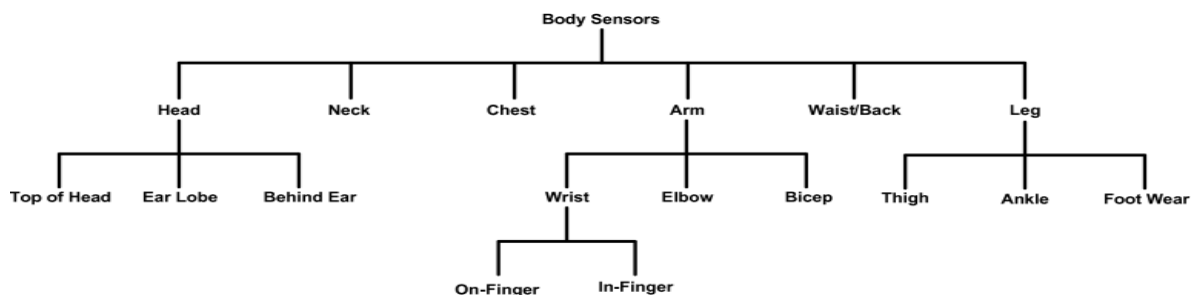

Figure 2. Hierarchy of Body Sensor Network

Form all above discussion it is concluded that the sensor placement issue is not yet been completely resolved, but depending on activity being monitored, optimum location for sensor placement can be found. Depending on the nature of activity, sensors can be divided into different activity groups. Table.1 shows some of common physical activities along with their activity groups. On the bases of experiments and available literature, common positions for particular activities are arm, wrist, bicep, chest, waist, leg, ankle,

thigh, head, ear lobe, shoulder and neck. These positions along with their activities shown in Table 2. Fig.2 shows the hierarchy of body sensors.

IV. DESIGN OF WEARABLE SENSORS

For efficient utilization of physician's resources and health related cost, researchers and experts propose the idea of ubiquitous health care system. Ubiquitous health care systems provide a smarter and cheaper way to efficiently deal with patients suffering from chronic diseases [15]. For implementation of this system wireless wearable or implantable sensors required to monitor patient activities. Currently researcher's main focus is to develop such sensors that are comfortable and non-invasive, utilize minimum energy and provide maximum and accurate results [16]. In following sections a brief survey of wearable sensors will be given regarding their design.

TABLE II. SENSOR PLACEMENTS AND ACTIVITIES

Sensor Type	Placement	Activity
Goniometer	Elbow	Elbow angle
Gyroscope	Waist, chest, back	Angular acceleration
Accelerometer	Waist, chest, leg, ankle	Linear acceleration
Megnatoresistive sensor	Waist, chest, leg	Change in body orientation
Pedometer	Leg	Step counting, hips motion
EMG Sensor	Leg, arm	Muscle activity during Gait/walking
Electronic Tracking System	Waist, leg, chest	Position of object
EEG Sensor	Head, behind ear	Brain activity signals
ECG Sensor	Chest, side of chest	ECG signals
PPG sensor	Finger , Earlobe	Volumetric measurement of blood
SpO2 sensor	Wrist	Oxygen saturation (SpO2)
Bio-sensor needle	Under skin	Blood Glucose level
Force sensor	Embedde`d in footwear	Measurement of Ground Reflection Force

A. Non-contact ECG/EEG Sensor Electrode

EEG and ECG signals from brain and heart are most critical parameters to be monitored in long term continuous health monitoring system by using wearable sensors. Conventionally wet EEG and ECG electrodes were used for monitoring signals, after some technological advancements use of dry electrodes instead of wet become common, but due to their continuous use some skin related problems arise. After this researchers divert their focus to develop minimal or non-invasive technique to measure these critical health parameters. In [11], authors develop a Non-contact (Capacitive) EEG/ECG wireless sensor electrode to detect signals from brain and heart. Upper Printed Circuit Board (PCB) contains a low noise amplifier and 16 bit Analog to Digital Converter (ADC) that output detected signals in digitized values. Whereas, lower PCB consists of amplifier (INA116), bottom surface of PCB filled with solid copper and insulated by soldermask, that works as electrodes to detect signals from surface.

In development of non-contact low noise electrode sensor, main challenge is to design an ultra-high input impedance and low noise amplifier. For this purpose authors of [11], design a circuit for electrode sensor. It consists of voltage source V_s that is connected to input of amplifier, who has coupling capacitance C_s with finite resistance R_b and input capacitance C_{in} . This amplifier has a positive feedback that is applied through C_n . Input voltage noise of amplifier is V_{na} , input current noise is I_{na} , whereas, additional current noise is given by I_{nb} . Total input noise of capacitive amplifier is given by this equation.

$$V_n^2 = V_{na}^2 \left(1 + \frac{C_{in} + C_n}{C_s}\right)^2 + \frac{i_{na}^2 + i_{nb}^2}{W^2 C_s^2} \quad (1)$$

As signals coming from human body have very low frequencies and even a small amount of current noise can cause huge input voltage noise.

They use bias free technique to match noise specifications of amplifier (INA116). However cut-off frequency was set to 0.7Hz with a gain of 2.02dB. To operate this electrode over different coupling distances they use positive feedback technique. Output from amplifier (INA116) is forwarded to another amplifier (LTC6078) passed through a high-pass amplifier having cut-off frequency of 0.1Hz with 40.01 dB gain. These electrodes connected to wireless base unit, that receives all data from electrodes and forward it to monitoring server. In this system possibility of getting extra noise from external sources is a problem.

B. PTT Based Blood Pressure Estimation

Pulse Transit Time (PTT) is a method use to estimate blood pressure non-invasively. PTT measure the time taken by a pulse wave to travel between two points in circulatory system. Pulse Wave Velocity (PWV) calculated using following equation.

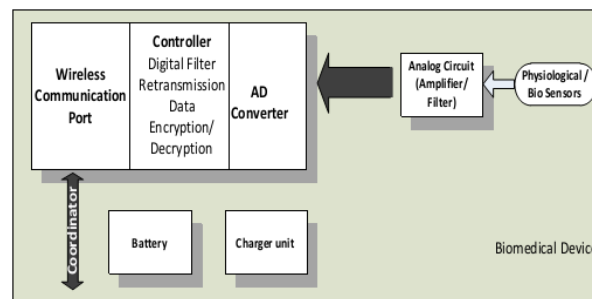

Figure 3. Functional Block Diagram

$$C^2 = \frac{\Delta p V}{\Delta v \rho} \quad (2)$$

where, C denotes PWV, Δp is change in pressure, V is the initial volume, Δv shows change in volume and ρ is density of fluid. PTT can be calculated as

$$PPT = \frac{1}{PWV} \quad (3)$$

In [17], authors develop a device that consists of several bio signal measuring modules. It has sensors to measure ECG, Photoplethysmograph (PPG) that measures changes occur in blood optically, skin temperature, fall detection and Non-Invasive Systolic Blood Pressure (NISBP). Micro-controller works as a central processor, which manage all operations of attached sensors. ECG sensor has two electrodes used to detect heart signals at two different locations on wrist. A flexible ribbon type sensor used to measure skin temperature. SpO2 sensor is attached on top of wrist band such that fingers of other hand easily touch on its surface to detect PPG signals from finger. This wearable device consists of micro-controller, signal detecting sensors, analog circuits, ADCs and wireless modules. A block diagram of this device is shown in Fig.3.

To measure ECG with the help of wrist worn device two electrodes adjusted in such a way that one electrode must sense signals from wrist on which patient wear this device, second electrode place on top of device such that other hand can easily touch surface of electrode. This ECG module consists of instrumentation amplifier, notch filter, and non-inverting amplifier with bandwidth of 50Hz. Detected signals is then digitized for transmission and evaluation.

To measure skin surface temperature, a flexible ribbon type sensor used, that is attached with inner surface of device such that sensor can touch patient skin to measure temperature. Whereas, fall detector sensor is a 3-axis accelerometer, when cumulative value of all axis reaches a threshold a fall event occurs. An increase in blood pressure increases PWV [18], by detecting this effect with the help of ECG and PPG systolic blood pressure can be measured.

C. Cuff-less PPG based Blood Pressure Monitoring

Cuff-based oscillometric devices used for continuous ambulatory blood pressure monitoring. To estimate blood pressure, relationship of external pressure (air filled bladder) with magnitude of arterial volume pulsation is used. However this traditional method is not suitable for long term monitoring. In [19] authors develop a PPG based non-invasive continuous blood pressure monitoring method. PPG uses optical signals to measure volumetric pulsation of blood in tissues. This device has some technical issues that must be noted. Measurement of Mean Arterial Pressure (MAP) requires an effective method to check volumetric changes in blood. To measure hydrostatic pressure offset against heart, a height sensor is required that should be wearable, compact in size and consume low power. Following equation is used to measure pressure difference across vascular wall.

$$P_{tm} = P_{MAP} - \rho \cdot g \cdot h - P_{cuff} \quad (4)$$

where, P_{tm} is Transmural Pressure, P_{MAP} is Mean Arterial Pressure, $\rho \cdot g \cdot h$ is pressure offset when location of measuring device is not as same as heart however this value will be omitted from equation if height of measuring device and heart have same height levels and P_{cuff} is pressure applied from external source. A known amount of pressure (below 75mmHg) is applied from cuff based device and when it matches with internal MAP, a large amplitude pulse is detected (Zero Transmural Pressure point). PPG is used to detect the changes in volume of blood vessels. To overcome the problem of applying large pressure across cuff, authors use the concept of raise and lower arm to alter pressure in vessels.

Authors define following procedure to measure blood pressure. By fixing pressure across cuff, PPG sensor worn arm is raised to check variations in reference pressure.

$$P_r = \rho \cdot g \cdot h + P_{cuff} \quad (5)$$

and PPG signal having highest amplitude shows zero transmural pressure point.

$$P_{MAP} = P_r = \rho \cdot g \cdot h + P_{cuff} \quad (6)$$

To precise motion of PPG worn arm, authors introduce accelerometer based arm movement control process. They attach two accelerometer sensors on arm; first accelerometer is attached on bicep area and second is on finger (embedded with PPG). Where, l_0 is distance from shoulder to heart, l_1 length of upper arm and l_2 is length of forearm.

Following equations use to measure height of PPG sensor with respect to heart.

$$h = l_1 \cdot \cos \theta_1 + l_2 \cdot \cos \theta_2 - l_0 \quad (7)$$

$$h = l_1 \cdot \sin \theta_1 + l_2 \cdot \sin \theta_2 - l_0 \quad (8)$$

D. sEMG Electrode based Sensor

In [20], authors design a sEMG electrode based sensor to check properties of bicep muscle with the help of goniometer sensor. Developed system consists of two parts. Amplification part contains an amplifier and filtering circuit as shown in Fig.4 and a SunSPOT that contains different circuitry for processing of received signals from bicep worn sEMG sensor.

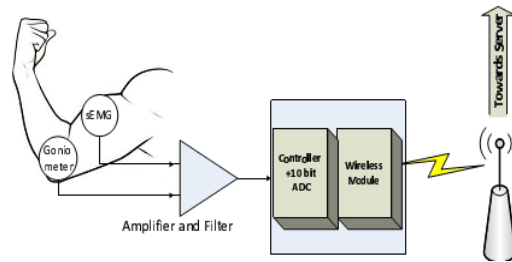

Figure 4. Overview of Hardware Architecture

Signals coming from body surface have very small peak to peak amplitude, to amplify these signals; amplifier is directly connected with leads coming from body surface. Received signals amplify about 330 times of original signals and filtered with 10 to 1000 Hz bandpass filter.

SunSPOT is a processing unit produced by Sun Microsystems that consists of a microcontroller and 10 bit ADC. Analogue signals coming from bandpass filter forwarded to ADC for conversion, and these converted signals send to server for processing via wireless medium.

V. ECG Noise removing filters

In health-care monitoring system, wearable sensors measure different types of physiological signals, like ECG, EEG, EMG etc. After passing through different devices and mediums, these signals contain different types of noises. For analysis of these signals, they must be in noise free form. For processing of these signals, a process or device named Filter is used to remove unwanted noise. Normally filters are used to

suppress aspects of signals completely or partially depending upon noise to be removed. However while filtering these signals, filters might remove required information associated with noise [21].

In digital signal processing applications, digital filters are most important elements. These digital filters might have been categorized as Finite Impulse Response (FIR) and Infinite Impulse Response (IIR) filters with respect to their duration of impulse responses.

A. FIR Filters

FIR filters are widely used due to their powerful design, inherent stability and linear phase. These filters have impulse response of finite durations, after this finite duration it settles to zero.

$$y[n] = b_0x[n] + b_1x[n - 1] + \dots + b_kx[n - k] \quad (9)$$

$$y[n] = \sum_{k=0}^M b_k x[n - k] \quad (10)$$

where, $x[n]$ is input signal, $y[n]$ is output signal, b_i is filter coefficients and N is the filter order. These filters output is only dependent upon present and previous values of input. However these filters have high complexity issues. FIR filter can be further classified into two categories: Window based methods and Frequency sampling domain methods [22]. However, only window based methods will be discussed briefly here.

1) *Kaiser Window*: The Kaiser window is an approximation to a restricted time duration function with minimum energy outside some specified band. If we have information about ripples and transition bandwidth then by using following equations we can find remaining parameters.

$$\alpha = -20 \log_{10}(\text{Amount of Ripples Allowed}) \quad (11)$$

where, α is side lobe attenuation in dB. Width of smallest transition region can be calculated by using this equation.

$$\Delta\omega = 2\pi \frac{\text{Transition Width}}{\text{Sampling Frequency}} \quad (12)$$

Now for filter order following equation is used

$$N = \begin{cases} \frac{\alpha - 7.95}{2.285\Delta\omega} & \text{if } \alpha > 21 \\ \frac{5.79}{\Delta\omega} & \text{if } \alpha \leq 21 \end{cases} \quad (13)$$

$$\beta = \begin{cases} 0.1102(\alpha - 8.7) & \text{if } \alpha > 50 \\ 0.582(\alpha - 21)^{0.4} + 0.07887(\alpha - 21) & \text{if } 21 \leq \alpha \leq 50 \\ 0 & \text{if } \alpha < 21 \end{cases} \quad (14)$$

where, β is parameter that affects the side lobe attenuation, increasing beta widens main lobe due to this attenuation will increase.

1) **Hanning Window:** The Hann or Hanning window, belongs to family named "raised cosine" windows, the term "Hanning window" is sometimes used to refer to Hann window. Coefficients of a Hanning window can be computed from following equation.

$$\omega(n) = 0.5 \left(1 - \cos \left(2\pi \frac{n}{N} \right) \right) \quad (15)$$

where, N is order of window.

2) **Hamming Window:** The "raised cosine" with these particular coefficients was proposed by Richard W. Hamming. Coefficients of a Hamming window can be computed from following equation.

$$\omega(n) = 0.54 - 0.46 \cos \left(2\pi \frac{n}{N} \right), 0 \leq n \leq N \quad (16)$$

where, N is order of window.

3) **Blackman Window:** In Blackman window side lobes rolloff at about 18dB per octave [22]. Coefficients of Blackman window are calculated as

$$\begin{aligned} \omega(n) = & 0.42 - 0.5 \cos \left(\frac{2\pi n}{2N+1} \right) \\ & + 0.08 \cos \left(\frac{4\pi n}{2N+1} \right), -N \leq n \leq N \end{aligned} \quad (17)$$

Number of terms for Blackman window is give as

$$N' = 5.98 \frac{f_s}{T.W} \quad (18)$$

where, f_s is sampling frequency and T. W is transition width.

4) **Blackman-Harris Window:** Blackman-Harris (BH) window family is generalization of Hamming family [22]. Coefficients of BH window are calculated as

$$\begin{aligned} \omega(n) = & 0.358 + 0.488 \cos \left(\frac{2\pi n}{N+1} \right) + 0.142 \cos \left(\frac{2\pi n}{N+1} \right) \\ & + 0.012 \cos \left(\frac{2\pi n}{N+1} \right) \end{aligned} \quad (19)$$

where, $-\frac{N}{2} \leq n \leq \frac{N}{2}$

B. IIR Filters

Digital filters which must be implemented recursively are called Infinite Impulse Response (IIR) filters because, theoretically, the response of these filters' to an impulse never settles to zero. IIR filters output completely depend upon previous inputs, present inputs and on previous outputs. These filters are very helpful for designing high speed signal processing, because these types of filters have less number of multiplications as compared to FIR filters. Difference equation or response of filter is given by following equation [23].

$$y[n] = - \sum_{k=1}^N a_k y[n - N] + \sum_{k=1}^M b_k x[n - M] \quad (20)$$

where, N is feedforward filter order, M is feedback filter order, a_i feedforward coefficient, b_i is feedback coefficient, $x[n]$ is input signal and $y[n]$ is output signal. First part of equation represents recursive part of IIR filter and second part shows non-recursive part. Different types of IIR filters will be discussed briefly here.

Butterworth Filter: Butterworth filters are characterized by a magnitude response that is maximally flat in the passband and monotonic overall. Decay is slow in passband and fast in stopband, due to this, it is preferable choice where low number of ripples required in pass and stopband.

$$|H(\omega)| = \left[\frac{1}{1 + \left(\frac{\omega}{\omega_c}\right)^{2N}} \right]^{\frac{1}{2}} \quad (21)$$

If we have values of pass and stopband attenuations and frequencies then by using this equation value of cut-off frequency and order of filter can be calculated. Values of cut-off frequency and order of filter then further used to calculate the filter transfer function.

1) **Chebyshev-I Filter:** In Chebyshev Type I faster roll-off can be acquired by allowing ripple in the frequency response. Analog and digital filters that use this approach are called Chebyshev filters. These filters are named from their use of Chebyshev polynomials, developed by Russian mathematician Pafnuti Chebyshev [24]. Chebyshev Type I filter has magnitude response given by following equation

$$|H(\omega)| = \frac{A}{\left[1 + \varepsilon^2 C_N^2 \left(\frac{\omega}{\omega_c} \right) \right]^{\frac{1}{2}}} \quad (22)$$

where, A is filter gain, ω_c is cut-off frequency, ε is a constant, and filter order can be calculated by using following equation

$$C_N(x) = \cos(N \cos^{-1} x), \text{ for } |x| \leq 1 \quad (23)$$

$$C_N(x) = \cosh(N \cosh^{-1} x), \text{ for } |x| \geq 1 \quad (24)$$

2) **Chebyshev-II Filter:** It is also known as inverse of chebyshev filter. Chebyshev Type II filters have ripple only in the stopband and it does not roll-off as fast as chebyshev Type I. Type II filters are seldom used.

$$|H(\omega)| = \frac{\varepsilon C_N \left(\frac{\omega_c}{\omega} \right)}{\left[1 + \varepsilon^2 C_N^2 \left(\frac{\omega_c}{\omega} \right) \right]^{\frac{1}{2}}} \quad (25)$$

where, ε is a constant and ω_c is 3dB cut-off frequency [24].

3) **Elliptical Filter:** Elliptic or Cauer filters exhibit equiripple behavior in both passband and stopband. This type of filter contains both poles and zeros and is characterized by magnitude response

$$|H(\omega)| = \left[\frac{1}{1 + \varepsilon^2 U_N \left(\frac{\omega}{\omega_c} \right)^{2N}} \right]^{\frac{1}{2}} \quad (26)$$

where, $U_N(x)$ is Jacobian elliptical function of order N , and ε is a parameter related to the passband ripple. The order of elliptic filter that is required to achieve given specifications is lower than order of Chebyshev and Butterworth filters. Therefore elliptical filters form an important class, but the design of this filter is more complex than other filters.

VI. SIMULATION AND RESULTS

Different types of heart diseases; like Arrhythmia, Bradycardia, Sinus Tachycardia and Premature Ventricular Contraction (PVC) etc., are figured out by using ECG pulse waveforms, which has different shapes for every specific diseases. There are many other types of filters and windows to remove noise from physiological signals, however due to simplicity we have selected previously mentioned filters and windows to remove noise from ECG signal.

Raw ECG record of 15 seconds duration selected that includes 5400 samples of subject 100. The experimental setup is divided into three parts, in first part ECG signals processed to remove baseline wander noise by designed FIR and IIR highpass filters, in second part high passed ECG signals passed through lowpass FIR and IIR filters to remove muscle noise artifact and in third part IIR notch filter used to remove 50/60 Hz power component noise as shown in Fig. 5[25].

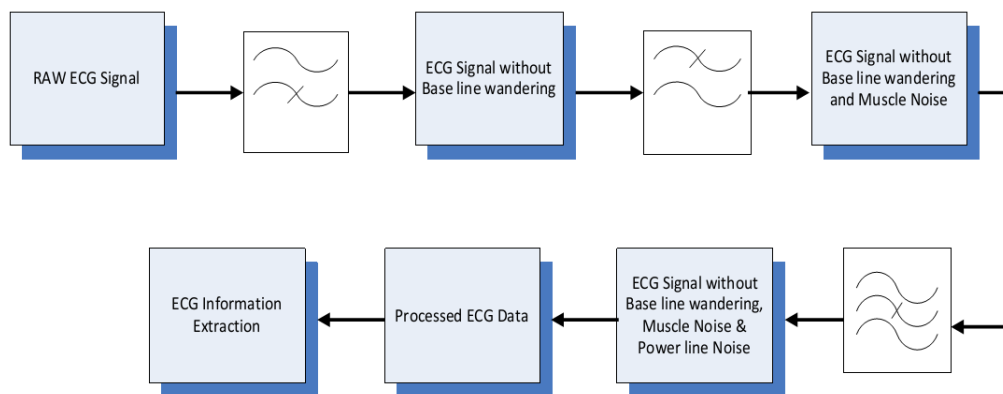

Figure 5. ECG Signal Processing Flow Diagram

FIR highpass and lowpass filters with Kaiser, Hanning, Hamming, Blackman and Blackman-Harris windows and IIR highpass and lowpass filters with Butterworth, Chebyshev type I, Chebyshev type II and Elliptical at sampling frequency 360Hz have been designed. Highpass filter used to remove low frequencies

of ranges 0.5 to 3 Hz, whereas, in low pass filters, cut-off frequency was set 100 Hz to remove high frequencies and 60 Hz power line noise was removed by using 60 Hz notch filter. Passband attenuation of 1dB and stop band attenuation of 80 dB (varies according to parameters) was selected with different filter orders depending on requirement. The MATLAB version 7.6.0, R2008a with signal processing and FDA toolbox was used for design of FIR filters. Fig.6 illustrates ECG signal that is corrupted by baseline wander, power line and muscle noise interferences sampled at 360 Hz.

The data source used in this study is obtained from Physio-Bank entitled MIT-BIH Arrhythmia Database available online. Source of ECG included in MIT-BIH Arrhythmia Database is a set of over 4000 long term holter recordings that were obtained by BethIsrael Hospital Arrhythmia Laboratory between 1975 and 1979 [26].

The subjects were 25 men aged 32 to 89 years, and 22 women aged 23 to 89 years. The bandpass-filtered signals were digitized at 360 Hz per signal relative to real time using hardware constructed at the MIT Biomedical Engineering Center and at the BIH Biomedical Engineering Laboratory. The sampling frequency chosen to facilitate implementations of 60 Hz digital notch filters in arrhythmia detectors.

A. Baseline Wander Noise Filtering

Baseline wander is also called low frequency noise. This is caused by the variation in distance between heart position and electrodes due to motion of arm. This noise is normally considered below 1 Hz. Baseline wander noise is removed by using highpass filters [25], [27].

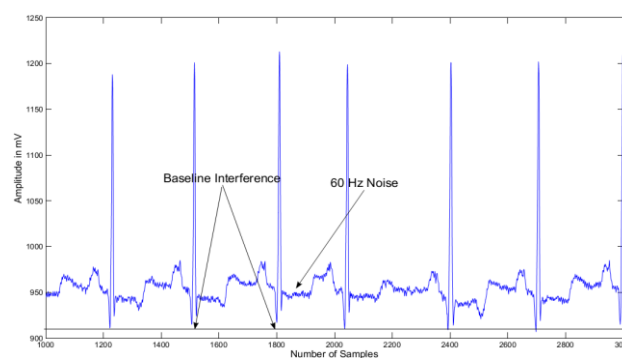

Figure 6. Original Signal with Noise

1) **Baseline Wander Cancellation by using IIR Highpass Filters:** In Fig.7 Butterworth highpass filtered ECG signal is shown, indicated arrow shows, the removal of baseline drift from original ECG signal. Similarly in Fig.8, 9 and 10 Chebyshev I, Chebyshev II and Elliptical filtered ECG signals shown respectively, these three filters have good output response for baseline noise removal, however Butterworth and Elliptical filter show good results as compared to other two.

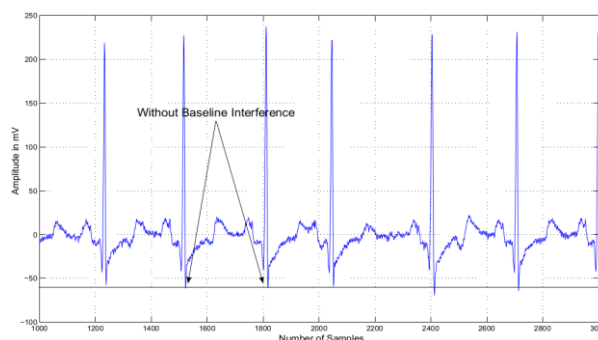

Figure 7. Butterworth Highpass Filter

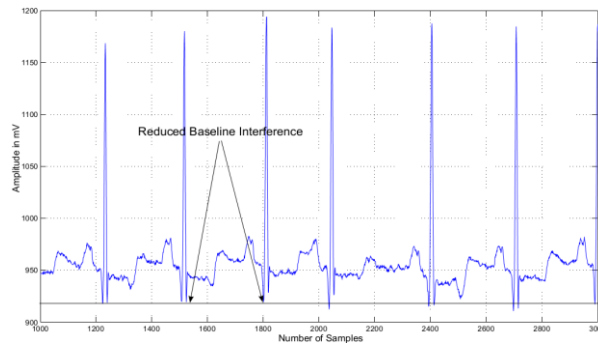

Figure 8. Chebyshev-I Highpass Filte

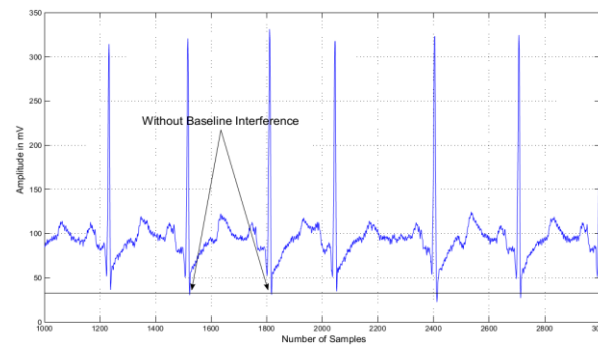

Figure 9. Chebyshev-II Highpass Filter

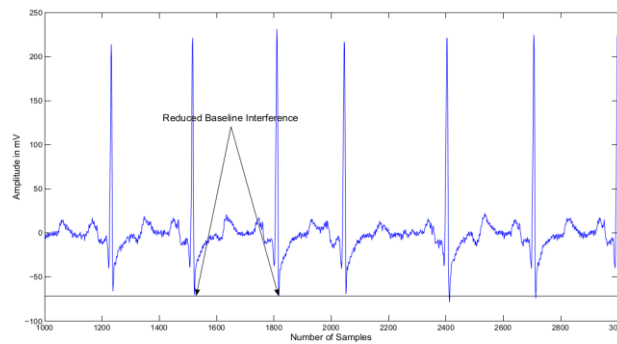

Figure 10. Elliptical Highpass Filter

1) **Baseline Wander Cancelation by using FIR Window based Highpass Filters:** In Fig. 11 FIR Kaiser window based highpass filtered output ECG signal is shown, figure shows it has reduced the baseline noise but not eliminated completely. Whereas, Fig. 12, 13, 14 and 15 show Hanning, Hamming, Blackman and Blackman-Harris window filtered output ECG signals with reduced baseline noise.

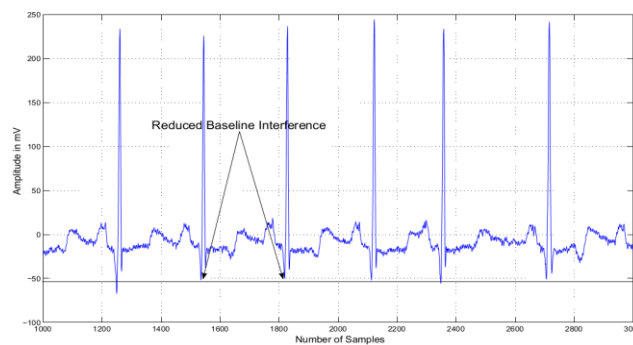

Figure 11. Kaiser Window based Highpass Filter

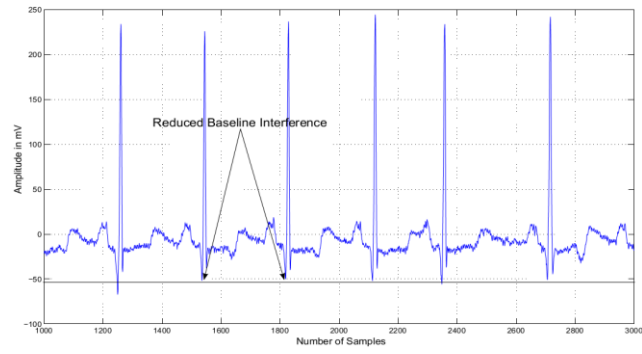

Figure 12. Hanning Window based Highpass Filter

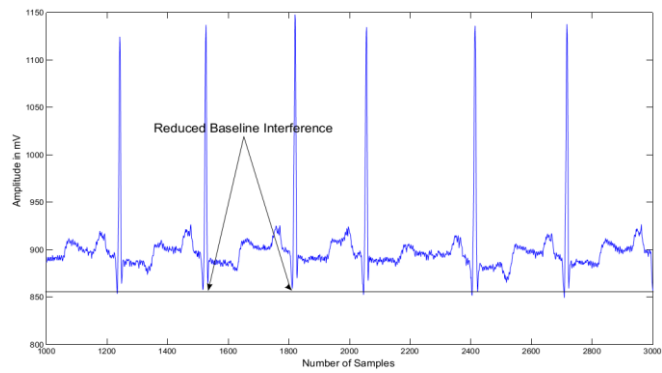

Figure 13. Hamming Window based Highpass Filter

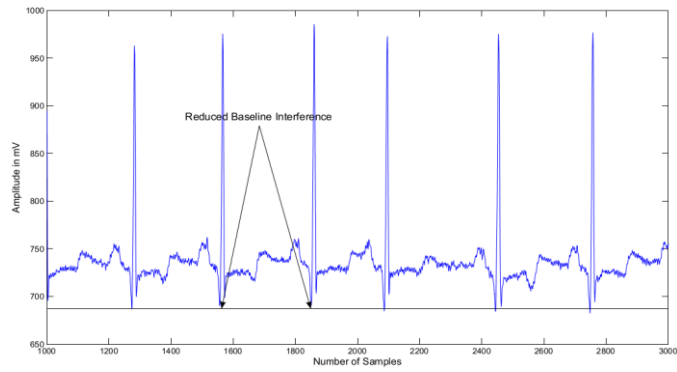

Figure 14. Blackman Window based Highpass Filter

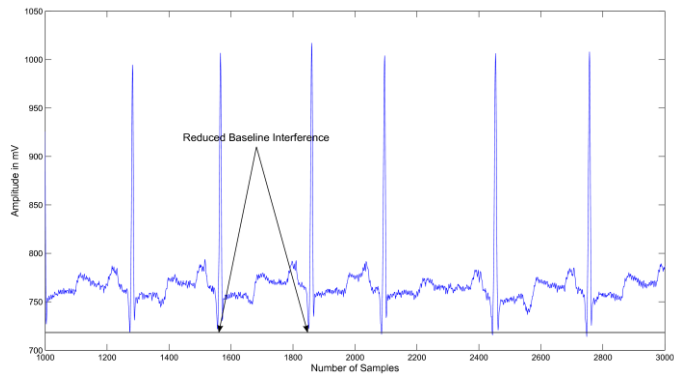

Figure 15. Blackman Harris Window based Highpass Filter

B. Muscle Noise(MN) Filtering

Muscle noise or EMG noise forms as a result of superposition phenomena of large number of action potentials inside muscles and these waveform coexists usually with ECG or other signals. Such samples occur as spikes with large value. These large values cause severe problems to low amplitude signals. Traditionally gaussian impulse response filters used to remove noise, however a lowpass filter with specific bandwidth can also be used, such that the QRS Complex remains unchanged [22]. In simulations, we use different FIR and IIR lowpass filters to compare resultant signals. As muscle noise forms due to high amplitude signals ranges from 100 to 500 Hz and an ECG signal normally have information in the range of 0.5 to 100 Hz, so a lowpass filter with 100 Hz stop frequency is used to remove Muscle Noise.

1) **Muscle Noise Cancellation by using IIR Lowpass Filters:** Fig. 16, 17, 18 and 19 shows a comparison of original ECGsignal that contains different noises with Butterworth, Chebyshev I, Chebyshev II and Elliptical lowpass filters. These filters are used to remove high frequency components from ECG signal.

According to simulation results, Butterworth and Elliptical remove high frequency components precisely, however Butterworth filter introduce some low frequency components in S wave regions. Whereas, Chebyshev I also shows good results and Chebyshev II filter reduced the high frequency components however QRS complex gets distorted as shown.

2) **Muscle Noise Cancellation by using FIR Window based Lowpass Filters:** In Fig. 20, 21, 22, 23 and 24 FIR filters with different windowing techniques for lowpass filters remov high frequency components. According to simulation results, all windowing techniques shows poor results as high frequency components gets reduced a bit however Kaiser and Hamming shows some good results as compared to other windowing filter techniques shown in figures.

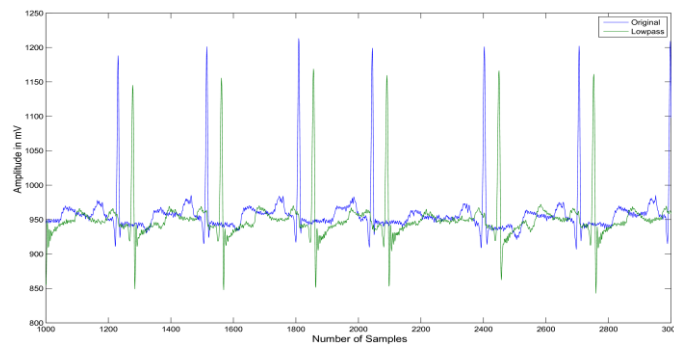

Figure 16. Butterworth Filtered Signal

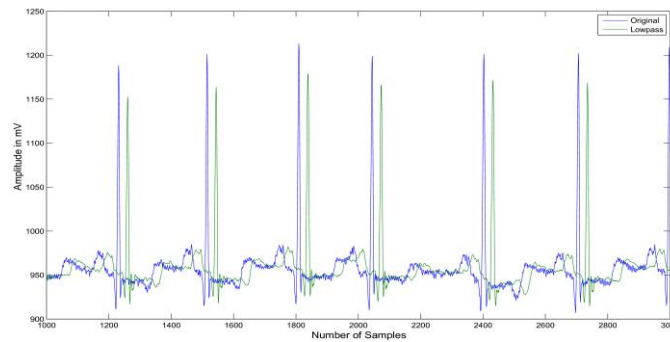

Figure 17. Chebyshev-I Filtered Signal

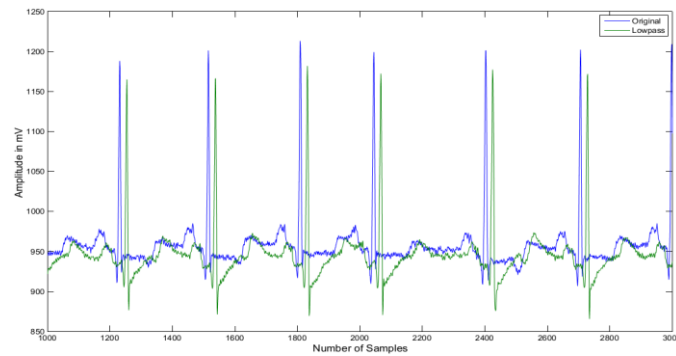

Figure 18. Chebyshev-II Filtered Signal

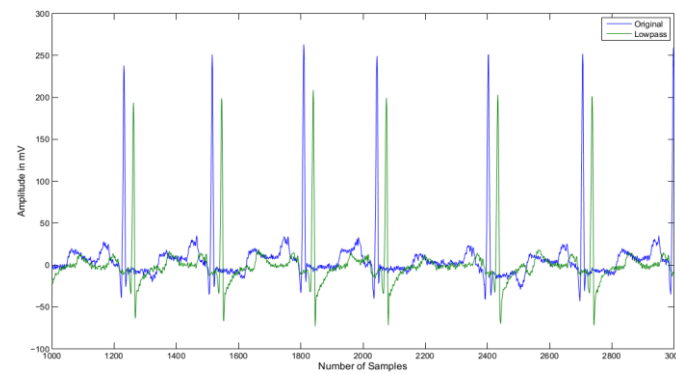

Figure 19. Elliptical Lowpass Filtered Signal

C. Power Line Interference (60 Hz) Filtering

Electromagnetic field of power line can cause 50/60 Hz sinusoidal interference; such interference causes problems while dealing with low amplitude waveforms. Notch filter is commonly used to cancel the effect of power line interference with cut-off frequency of 50/60 Hz [28].

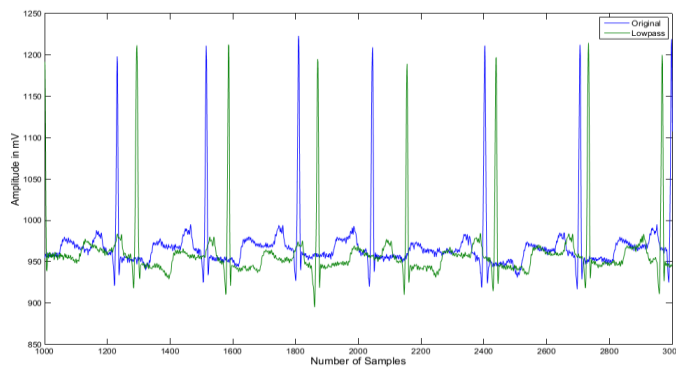

Figure 20. Kaiser Window based Filtered Signal

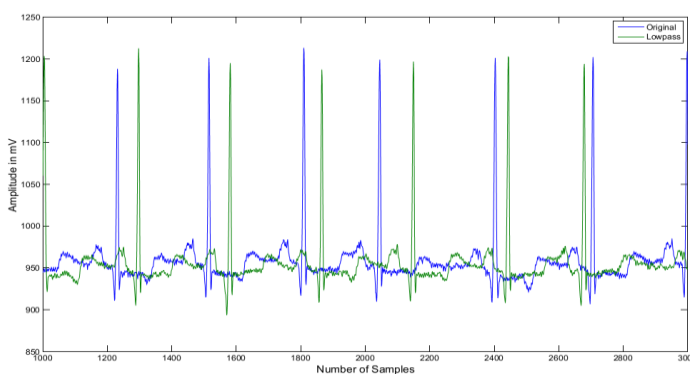

Figure 21. Hanning Window based Filtered Signal

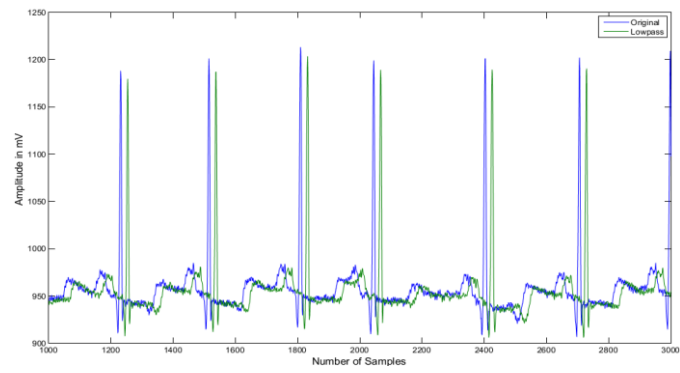

Figure 22. Hamming Window based Filtered Signal

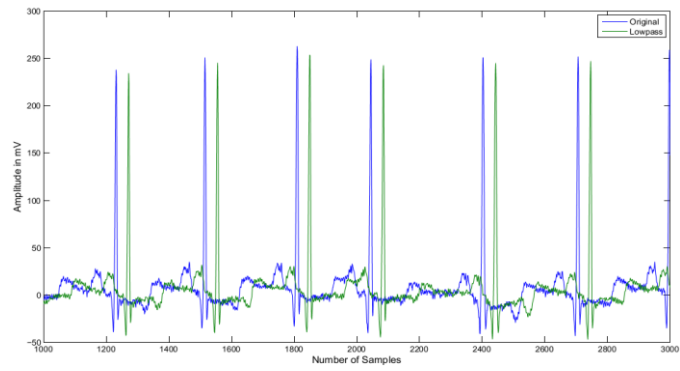

Figure 23. Blackman Window based Filtered Signal

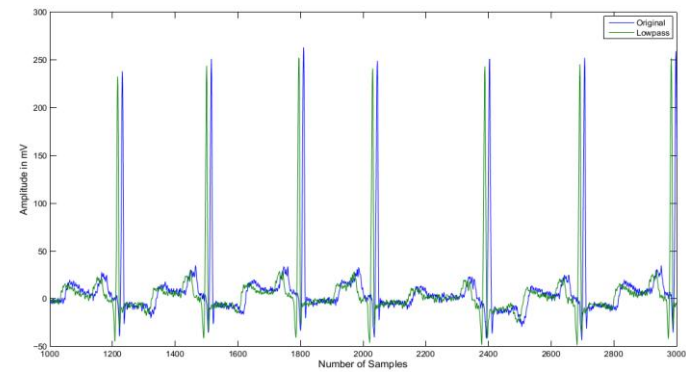

Figure 24. Blackman Window based Filtered Signal

1) **Power Line Interference cancellation by using Notch Filter:** In Fig. 25 we used IIR Notch filter to remove 60 Hz interference from signals that have already been passed from different filters and windows like Butterworth, Chebyshev I, Chebyshev II, Elliptical, Kaiser, Hanning and Hamming, Blackman and Blackman-Harris respectively. According to simulation results IIR notch filter completely remove 60 Hz power line interference from ECG signals as shown by indicated arrow in figure.

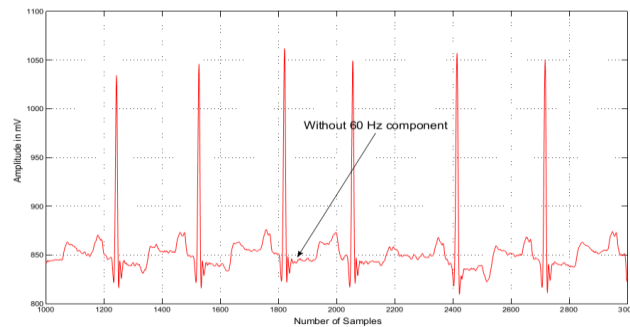

Figure 25. 60 Hz Notch Filter

VII. CONCLUSION AND FUTURE WORK

In this paper Wireless Wearable sensors has been discussed with respect to different motion detection scenarios and a brief survey of wireless wearable sensor designs. At the end we designed Lowpass, Highpass and Notch filters for both IIR (Butterworth, Chebyshev I, Chebyshev II and Elliptical) and FIR based on windowing techniques (Kaiser, Hanning, Hamming, Blackman and Blackman-Harris) to remove noise from raw ECG signals. In IIR filters, Butterworth, Chebyshev and Elliptical shows good results whereas, window based Kaiser filter shows good results in FIR filter.

In this paper, Analysis of only one type of disease is presented i.e. Arrhythmia disease. There are many other heart diseases, analysis of signals obtained from these diseases has been left for future.

References

- [1] Rehman, A., M. Mustafa, N. Javaid, U. Qasim, and Z. A. Khan. "Analytical Survey of Wearable Sensors." arXiv preprint arXiv:1208.2376 2012.
- [2] T. Yilmaz, R. Foster, and Y. Hao, "Detecting vital signs with wearable wireless sensors," Sensors, vol. 10, no. 12, pp. 10837–10862, 2010.
- [3] P. Oberg and T. Togawa, Sensors in medicine and health care, vol. 3. Vch Verlagsgesellschaft MbH, 2004.
- [4] A. Godfrey, R. Conway, D. Meagher, and G. O'Laighin, "Direct measurement of human movement by accelerometry," Medical engineering & physics, vol. 30, no. 10, pp. 1364–1386, 2008.

- [5] A. Casson, S. Smith, J. Duncan, and E. Rodriguez-Villegas, "Wearableeeg: what is it, why is it needed and what does it entail?," in Engineering in Medicine and Biology Society, 2008. EMBS 2008. 30th Annual International Conference of the IEEE, pp. 5867–5870, IEEE, 2008.
- [6] F. Raab, E. Blood, T. Steiner, and H. Jones, "Magnetic position and orientation tracking system," Aerospace and Electronic Systems, IEEE Transactions on, no. 5, pp. 709–718, 1979.
- [7] W. Tao, T. Liu, R. Zheng, and H. Feng, "Gait analysis using wearable sensors," Sensors, vol. 12, no. 2, pp. 2255–2283, 2012.
- [8] P. Veltink, C. Liedtke, E. Droog, and H. van der Kooij, "Ambulatory measurement of ground reaction forces," Neural Systems and Rehabilitation Engineering, IEEE Transactions on, vol. 13, no. 3, pp. 423–427, 2005.
- [9] C. Liedtke, S. Fokkenrood, J. Menger, H. van der Kooij, and P. Veltink, "Evaluation of instrumented shoes for ambulatory assessment of ground reaction forces," Gait & posture, vol. 26, no. 1, pp. 39–47, 2007.
- [10] R. Davis III, "Clinical gait analysis," Engineering in Medicine and Biology Magazine, IEEE, vol. 7, no. 3, pp. 35–40, 1988.
- [11] Y. Chi and G. Cauwenberghs, "Wireless non-contact eeg/ecg electrodes for body sensor networks," in Body Sensor Networks (BSN), 2010 International Conference on, pp. 297–301, Ieee, 2010.
- [12] W. Chung, Y. Lee, and S. Jung, "A wireless sensor network compatible wearable u-healthcare monitoring system using integrated eeg accelerometer and spo₂," in Engineering in Medicine and Biology Society, 2008. EMBS 2008. 30th Annual International Conference of the IEEE, pp. 1529–1532, IEEE, 2008.
- [13] C. Yang and Y. Hsu, "A review of accelerometry-based wearable motion detectors for physical activity monitoring," Sensors, vol. 10, no. 8, pp. 7772–7788, 2010.
- [14] L. Atallah, B. Lo, R. King, and G. Yang, "Sensor positioning for activity recognition using wearable accelerometers," Biomedical Circuits and Systems, IEEE Transactions on, vol. 5, no. 4, pp. 320–329, 2011.
- [15] J. Schepps and A. Rosen, "Microwave industry outlook-wireless communications in healthcare," Microwave Theory and Techniques, IEEE Transactions on, vol. 50, no. 3, pp. 1044–1045, 2002.
- [16] E. Lubrin, E. Lawrence, and K. Navarro, "Wireless remote healthcare monitoring with motes," in Mobile Business, 2005. ICMB 2005. International Conference on, pp. 235–241, IEEE, 2005.
- [17] Y. Kim and J. Lee, "Cuffless and non-invasive estimation of a continuous blood pressure based on ptt," in Information Technology Convergence and Services (ITCS), 2010 2nd International Conference on, pp. 1–4, IEEE, 2010.
- [18] D. Wei, G. Saidel, and S. Jones, "Optimal design of a thermistor probe for surface measurement of cerebral blood flow," Biomedical Engineering, IEEE Transactions on, vol. 37, no. 12, pp. 1159–1172, 1990.
- [19] P. Shaltis, A. Reisner, and H. Asada, "Wearable, cuff-less ppg-based blood pressure monitor with novel height sensor," in Engineering in Medicine and Biology Society, 2006. EMBS'06. 28th Annual International Conference of the IEEE, pp. 908–911, IEEE, 2006.
- [20] M. Al-Mulla, F. Sepulveda, and M. Colley, "An autonomous wearable system for predicting and detecting localised muscle fatigue," Sensors, vol. 11, no. 2, pp. 1542–1557, 2011.
- [21] A. Mashaghi, P. Vach, and S. Tans, "Noise reduction by signal combination in fourier space applied to drift correction in optical tweezers," Review of Scientific Instruments, vol. 82, no. 11, pp. 115103–115103, 2011.
- [22] K. CHINCHKHEDE, G. YADAV, S. HIREKHAN, and D. SOLANKE, "On the implementation of fir filter with various windows for enhancement of ecg signal," International Journal of Engineering Science, vol. 3, 2011.
- [23] M. Kaur, B. Singh, J. Ubhi, and S. Rani, "Digital filtration of ecg signals for removal of baseline drift," in Proceedings of International Conference on Computer Communication and Management (ICCCM 2011), 2011.
- [24] M. Chavan, R. Agarwala, and M. Uplane, "Comparative study of chebyshevi and chebyshev ii filter used for noise reduction in ecg signal," International Journal of Circuits, Systems and Signal Processing, no. 1, pp. 1–17, 2008.

- [25] M. Chavan, R. Aggarwala, and M. Uplane, "Suppression of baseline wander and power line interference in ecg using digital iir filter," *International Journal of Circuits, Systems And Signal Processing*, no. 2, pp. 356–65, 2008.
- [26] G. Moody and R. Mark, "The impact of the mit-bih arrhythmia database," *Engineering in Medicine and Biology Magazine, IEEE*, vol. 20, no. 3, pp. 45–50, 2001.
- [27] M. Kaur, B. Singh, et al., "Comparison of different approaches for removal of baseline wander from ecg signal," in *Proceedings of the International Conference & Workshop on Emerging Trends in Technology*, pp. 1290–1294, ACM, 2011.
- [28] A. Vale-Cardoso and H. Guimarães, "The effect of 50/60 hz notch filter application on human and rat ecg recordings," *Physiological measurement*, vol. 31, p. 45, 2010.